

JUN -- 2004 4830-1  
OWNER'S MANUAL  
4830

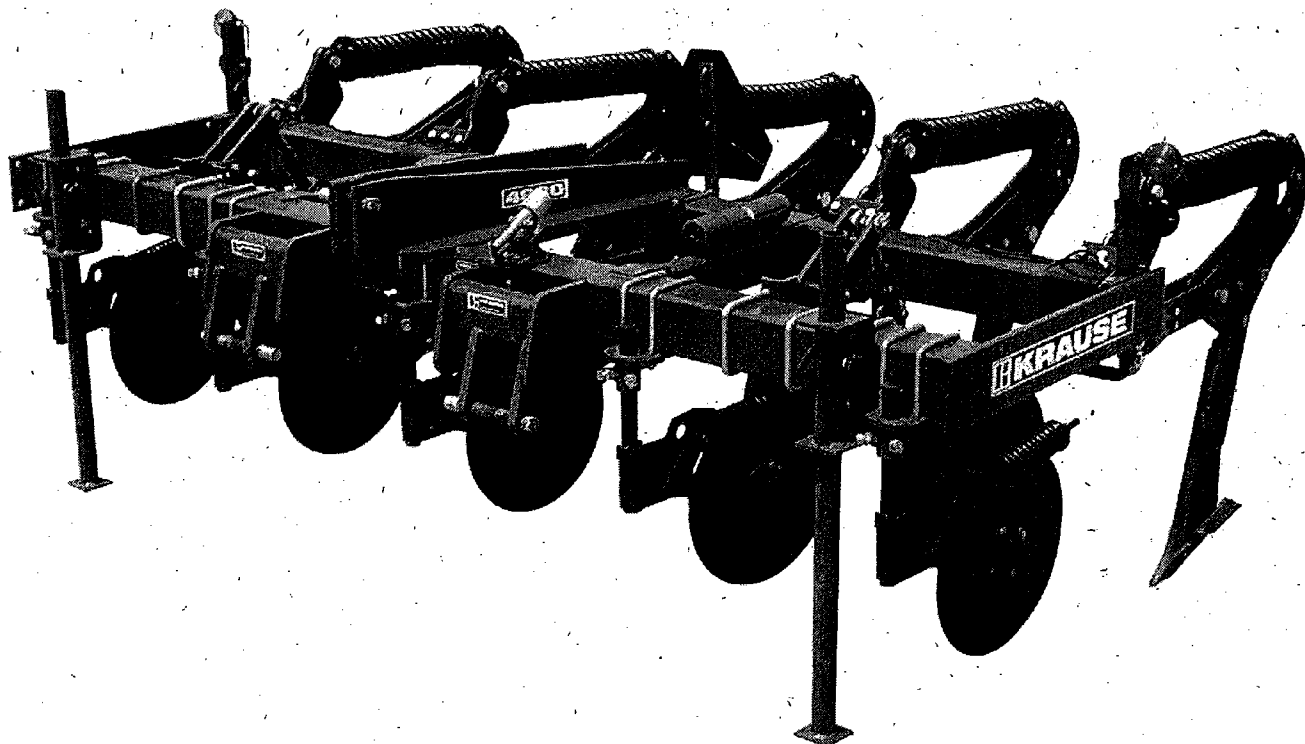

# IN-LINE RIPPER

## 4830 SERIES

# KRAUSE

305 SOUTH MONROE / P.O. BOX 2707 / HUTCHINSON, KS 67504-2707

# *Congratulations*

You have just purchased a quality designed and manufactured Krause tillage tool. Advanced features have been designed into the implement for modern farming operations. As with any investment, a return is expected, and the return received from this investment will be in the form of maximum tillage performance during many years of dependable service.

In order to maintain quality performance of the new Krause implement, it is important that all of the information in the manual be reviewed and studied carefully before operation. The contents provide operating instructions, maintenance instructions, and information on how to make adjustments.

## **SAFETY ALERT SYMBOL**



MODEL NUMBER \_\_\_\_\_ SERIAL NUMBER \_\_\_\_\_

PURCHASE RECORD - - DATE \_\_\_\_\_

## A note to our customers, parts managers and dealers:

This manual has been prepared to assist you in the proper use, daily care, and operation of your new Krause equipment. It contains specific information on the many built-in features of your equipment, the accessories and options that are available, general specifications, and instructions for making minor adjustments.

Read this manual carefully before operating your Krause equipment, and keep it in a convenient location for later reference.

In order to ensure that you have the most current operation manual available for your implement, we have added a revision code to each manual. Please note the information listed below and specify when placing service calls or ordering parts.

Manual for Model: 4830

This manual covers models beginning with Serial No. 1001

Operation Manual #: 4830-1

Parts Manual #: 4830-2

Rev.:

ISSUED TO:

ISSUED BY:

\_\_\_\_\_  
*Owner's Name*

\_\_\_\_\_  
*Krause Dealer*

\_\_\_\_\_  
*Mailing Address*

\_\_\_\_\_  
*City*

\_\_\_\_\_  
*City*

\_\_\_\_\_  
*State*

\_\_\_\_\_  
*State*

\_\_\_\_\_  
*Date of Purchase*



# Warranty Policy

(Krause Serial Numbered Wholegoods purchased subsequent to 7/1/99)

Note: All warranty work must be accomplished by a Krause Corporation Authorized Service Center rated to perform maintenance on Krause Corporation Products.

## A. KRAUSE CORPORATION ("KRAUSE") LIMITED WARRANTY.

- (1) Subject to the limitations and conditions hereinafter set forth, Krause warrants, at the time of delivery by Krause to be free from (i) defects in materials or workmanship, and (ii) defects in design that in the view of the state of the art as of the date of manufacture should have been foreseen provided, however, that the defect must be discovered and reported to Krause within the periods specified as follows. For a period of one year all new serial numbered production agricultural units covered by this warranty; for a period of thirty-six (36) months the tongue weldment, center frame weldment, wing frame weldments, disc harrow gang bearings and K-Tine field cultivator shanks.
  - (2) Krause does not warrant disc blades, shanks, hydraulic cylinders, accessories and other parts not manufactured by it, but supplied with or as a part of its products. Krause will, however, obtain and pass on any adjustments provided by the manufacturers of such parts under these manufacturer's warranties. Tires supplied on Krause products, will be warranted by the tire manufacturer's retail outlets.
  - (3) The entire extent of Krause's liability shall be limited to that of either reimbursing Buyer for its costs of purchasing a rebuilt, over-hauled or repaired part from either Krause or a proper Krause Authorized Service Center or, at Krause's election, reimbursing buyer for its costs of having the part repaired at a proper Krause Authorized Service Center. If Krause elects not to repair the part and if neither a rebuilt, over-hauled or repaired part is, in Krause's opinion, timely available then Krause will reimburse buyer for its costs of purchasing a new part from either Krause or a proper Krause Authorized Service Center. The labor necessary to remove from the product such part or parts and to install in the product such part or parts, as well as any repair made as the result of improper installations by Krause, shall be covered by this warranty, provided the work is performed at a proper Krause Authorized Service Center.\* If return of the defective part is required, it must be returned shipping prepaid to Krause. Krause's limited warranty will apply to any part repaired or replaced by a proper Krause Authorized Service Center pursuant to Krause's Limited Warranty: however, the applicable warranty for such part repaired or replaced shall be limited to the unexpired portion of Krause's Limited Warranty described in paragraph (1) or (2) above, as applicable. In other words, the warranty period of the part repaired or replaced does not start over from the date of reinstallation.
- \*[Krause Corporation will repair or replace, free of charge, any part of the product found to be defective, within the specified warranty periods, after an inspection of the part has deemed it to be defective. Inspection must be performed by an authorized agent of Krause Corporation, or returned to the Krause factory for inspection and disposition. Warranty labor will be considered during the first year of warranty only. Krause Corporation will establish and publish an hourly flat rate for shop labor and reimbursement during the first year of the warranty period. Krause Corporation does not allow credit for the cost of travel time, mileage or hauling as a warranty allowance. During the remaining second and third year, when applicable, Krause will repair or replace the defective part, without consideration of labor charges.]
- (4) Routine services (such as inspections, field settings, adjustments, etc.) and replacement of items which deteriorate from expected normal wear and tear or exposure (such as paint, tires, hoses, blades, sweeps, etc.) are not covered by this Limited Warranty. Such routine services and replacements required during the course of operation are not considered to be the result of any defect in the product.

## **B. LIMITATIONS APPLICABLE TO KRAUSE'S LIMITED WARRANTY.**

- (1) Krause will be relieved of all obligations and liability under this warranty if:
  - (i) The alleged defect in the part is due to misuse or neglect on the part of someone other than Krause; or
  - (ii) Krause's identification mark or name or serial number has been removed from the part in question; or
  - (iii) The product and/or equipment have not been maintained, operated or stored either in accordance with applicable manuals, communications or other written instructions of Krause or any manufacturer of the part involved, or in accordance with applicable regulations and advisory circulars unless buyer shows that such maintenance, operation or storage was not a contributory cause of the defect; or
  - (iv) The part in question has been modified or altered after delivery other than by the manufacturer or in accordance with a modification or alternation scheme approved in writing by the manufacturer; or
  - (v) The product is used for purposes other than conventional owner/operator usage. Usage not considered conventional owner/operator includes, but is not limited to, operation conditions that consist of rocks or other obstructions.
- (2) For the purpose of this Warranty, no part of the product or equipment will be regarded as breaching the limited warranty merely because, subsequent to its delivery, some modification or alteration becomes necessary for product improvements or in order to meet a change in the requirements of any applicable regulation.
- (3) TO THE EXTENT ALLOWED BY APPLICABLE LAW, BUYER WAIVES AS TO KRAUSE ALL OTHER WARRANTIES, WHETHER OF MERCHANTABILITY, FITNESS OR OTHERWISE, THERE ARE NO WARRANTIES WHICH EXTEND BEYOND THE DESCRIPTION ON THE FACT HEREOF.
- (4) TO THE EXTENT ALLOWED BY APPLICABLE LAW, THE OBLIGATIONS OF KRAUSE SET FORTH HEREIN SHALL BE THE EXCLUSIVE REMEDIES FOR ANY BREACH OF WARRANTY HEREUNDER, AND, TO THE SAME EXTENT, KRAUSE SHALL NOT BE LIABLE FOR ANY GENERAL, CONSEQUENTIAL OR INCIDENTAL DAMAGES, INCLUDING, WITHOUT LIMITATION, ANY DAMAGES FOR DIMINUTION OF MARKET VALUE, LOSS OF USE OR LOSS OF PROFITS, OR ANY DAMAGES TO THE PRODUCT CLAIMED BY BUYER OR ANY OTHER PERSON OR ENTITY UPON THE THEORIES OF NEGLIGENCE OR STRICT LIABILITY IN TORT.
- (5) ANY ACTION BY BUYER FOR BREACH OF THIS WARRANTY BY EITHER KRAUSE OR SELLER MUST BE COMMENCED WITHIN (1) YEAR AFTER THE CAUSE OF ACTION ACCRUES.

# Establishing Customer Warranty

## Dealer's Obligation

1. It is the responsibility of the dealer to complete a **Delivery Report and Warranty Registration** form. The form should contain the model, serial number, delivery date, along with the complete dealer and customer address. This form must be signed by the dealer and customer upon physical delivery of the product to the customer. The dealer must complete the **pre-delivery check list** provided on the Delivery Report and Warranty Registration form.
2. Dealer will review the **Predelivery Check List** located in the front of the operation manual with the customer and / or operator. This should be signed by the dealer at time of delivery to the retail customer.
3. The dealer will review the **Customer Review Sheet** located at the front of the operation manual with the customer and / or operator. This should be signed by the dealer representative and the customer.
4. An authorized Krause dealer will submit **warranty claims** on behalf of the customer. All claims must be handled through the dealer. They will then be given to the Krause District Manager for inspection and approval. Warranty requests must be filed within 60 days from completion of the repair for consideration.
5. It is the dealer's responsibility to **service** the warranty on products sold through said dealership.

This warranty gives you specific rights, and you may also have other rights which vary from state to state.

# Establishing Customer Warranty

## Customer's Obligation

1. The customer is responsible for reading the operation manual supplied with each serial numbered unit. The manual describes the safe and correct operating procedures of the specific product. The operation manual will also instruct the user on recommended lubrication and maintenance of the product.
2. The customer will advise the dealer of the anticipated start date of the product so a dealer representative can be on hand to make necessary field adjustments.
3. The owner is also responsible for inspecting the product during and after use. If a part has failed or is in need of repair, it should be replaced. When continued use of the product would result in excessive wear of other components, the part should be replaced before operation is continued. Continued use of the product may void warranty on other parts damaged from this condition. The user must make the machine available to the dealer for a warranty repair.
4. It is the customer's responsibility to deliver his machine to an authorized Krause dealer for completion of a warranty repair. If the dealer agrees to make a service trip to the customer's residence, it is an agreement between the dealer and the customer. Krause will not allow warranty credit for the cost of travel, mileage, or hauling.
5. Warranty labor consideration will only be given during the first year of warranty. Any labor charge for the 2nd or 3rd year on the limited warranty will be at the customer's expense.

This warranty gives you specific rights, and you may also have other rights which vary from state to state.

# 4830 IN-LINE RIPPER DEALER PREDELIVERY CHECK SHEET

TO BE CHECKED BY DEALER

CUSTOMER \_\_\_\_\_ DATE \_\_\_\_\_

ADDRESS \_\_\_\_\_

DEALER \_\_\_\_\_

ADDRESS \_\_\_\_\_

MODEL \_\_\_\_\_ SERIAL NUMBER \_\_\_\_\_

## DEALER CHECK:

### All Units:

1. \_\_\_ Check to see that all bolts are tight and pins are in place.
2. \_\_\_ All safety decals are in place and easily visible.
3. \_\_\_ Customer review sheet is filled out and signed.
4. \_\_\_ Review lighting requirements. Light kits are standard.
5. \_\_\_ Check to see that the Operation Manual is in the storage canister on the implement.
6. \_\_\_ Make sure that the SMV emblem and lights are clean and in place.
7. \_\_\_ Check lights for proper operation.

### Folding Units:

8. \_\_\_ Check to see that hydraulic cylinders are full of oil (air bled out of cylinders). Clevis pins with hair pin clips should be in place. Hydraulic system requires 8 Quarts of oil.
9. \_\_\_ Examine hydraulic hoses to see that they are protected from damage.
10. \_\_\_ Make sure wing hinges and wing lift parts are properly secured.
11. \_\_\_ Restrictors should be installed in wing lift cylinder ports.

### Optional Pull Hitch:

12. \_\_\_ Check to see that hydraulic cylinders are full of oil (air bled out of cylinders). Clevis pins with hair pin clips should be in place. This option requires 6 Quarts of oil.
13. \_\_\_ Examine hydraulic hoses to see that they are protected from damage.
14. \_\_\_ Check lug bolts holding wheels to the hub to see that they are torqued to 120 Ft. Lbs.
15. \_\_\_ The correct size tires, 11L x 15, 8-Ply inflated to 36 PSI pressure should be on the implement.
16. \_\_\_ Check to see that bolts attaching clevis to the hitch are tightened.
17. \_\_\_ Jack should be operational for support of tongue when implement is not attached to a tractor.
18. \_\_\_ Safety Chain is in place.

DELIVERED BY \_\_\_\_\_

DATE \_\_\_\_\_

# 4830 IN-LINE RIPPER CUSTOMER REVIEW SHEET

CUSTOMER \_\_\_\_\_ DATE \_\_\_\_\_

ADDRESS \_\_\_\_\_

DEALER \_\_\_\_\_

ADDRESS \_\_\_\_\_

MODEL \_\_\_\_\_ SERIAL NUMBER \_\_\_\_\_

1. Operation Manual provided.
2. Warranty card filled out and mailed.
3. Review safety warnings and cautions as listed in this Operation Manual.
4. Review recommended maximum road speed, width, and height for this implement.
5. Review field operational speeds, horsepower, depth and rock conditions.
6. Demonstrate the proper use of wing lock-down pins.
7. Review limitations of additional weight and transport speed due to additional weight on rear of tractor.
8. Explain the importance of maintaining the implement through lubrication, checking that bolts are kept tight, and replacement of worn or broken parts.
9. Explain lighting requirements for your area.

Optional Pull Hitch:

10. Recommend that the safety chain be used with the implement.
11. Check wheel lug bolts frequently until they become set.
12. Review hitching, unhitching and transport procedures with pull hitch.

DEALER \_\_\_\_\_ DATE \_\_\_\_\_

CUSTOMER \_\_\_\_\_ DATE \_\_\_\_\_

# Table of Contents

Rev.6/04

<b>Warranty</b>		REPAIR PARTS	O9
<b>Dealer Predelivery Check Sheet</b>	1	SUGGESTED REMEDIES SECTION	O10
<b>Customer Review Sheet</b>	2		
<b>Table Of Contents</b>	3	<b><u>PARTS SECTION</u></b>	
<b>Specifications</b>	4	RIGID FRAME	P1
<b>Safety Decals</b>	5	FOLDING FRAME	P2
		FOLDING FRAME - (836F, 838F, 840F & 930F)	P3
		RIGID WINGS & FOLDING WING FRAMES	P4
		WING FOLD ASSEMBLY	P5
		PULL HITCH ROCKER ASSEMBLY	P6-P7
		PULL HITCH	P8-P9
		GAGE WHEEL ASSEMBLY	P10-P11
		SPRING RESET SHANK ASSEMBLY	P12
		PATHFIND'R™ SHANK ASSEMBLY	P13
		SHEAR BOLT SHANK ASSEMBLY	P14
		SHANK STAGGER WELDMENT	P15
		RIPPER CLOSING WHEEL ASSEMBLY	P16-P17
		COULTER ASSEMBLY	P18-P19
		HYDRAULICS:	
		FOLDING FRAME	P20
		RIGID FRAME & PULL HITCH	P21
		FOLDING FRAME & PULL HITCH	P22-P23
		HYDRAULIC HOSE W/ PLASTIC GRIPS	P24
		4" X 16" PRINCE HYDRAULIC CYLINDER	P25
		4" X 10" PRINCE HYDRAULIC CYLINDER	P26
		4-1/4" X 10" PRINCE HYDRAULIC CYLINDER	P27
		LIGHT KITS	P28-P29
		DECALS	P30
		<b><u>ASSEMBLY SECTION</u></b>	
		FOLD LINKAGES & HYDRAULICS	A1
		Hydraulics	A1
		PULL HITCH ASSEMBLY	A2
		Lift Wheel Mount Locations	A2
		Hydraulics	A2
		SHANK STAGGER KIT	A3
		DECAL ATTACHMENT & SMV EMBLEM	A3
		Light Kit	A3
<b>OPERATING SECTION</b>			
SAFETY FIRST	O1		
OPERATING INSTRUCTIONS	O2		
ABOUT YOUR IN-LINE RIPPER	O2		
TILLAGE DEPTH	O2		
PREPARING THE RIPPER FOR OPERATION	O2		
PREPARING TRACTOR FOR OPERATION	O2		
ATTACHING RIPPER TO THE TRACTOR	O3		
Tractor Without Quick Coupler	O3		
Tractor With Quick Coupler	O3		
DETACHING THE RIPPER FROM TRACTOR	O3		
OPTIONAL PULL HITCH	O4		
HITCHING AND UNHITCHING	O4		
Hitching To The Tractor	O4		
Unhitching From The Tractor	O4		
TRANSPORTING	O5		
Transporting With Pull Hitch	O5		
Raising The Wings	O5		
Lowering The Wings	O5		
Depth Adjustment	O6		
Coulter Adjustment	O6		
Pull Hitch Adjustment	O6		
Closing Wheels Adjustment	O6-O7		
HYDRAULIC SAFETY ( <b>Read Carefully</b> )	O7		
Avoid Heating Near Pressurized Hoses	O8		
FERTILIZER EQUIPMENT	O8		
SERVICING	O8		
General Maintenance	O8		
Wheel Bearings	O9		
Coulter Hubs	O9		
Grease Points	O9		

## 4830 IN-LINE RIPPER SPECIFICATIONS

4/01

Model	Number of Shanks	Row Spacing	Swath	Main-frame Model	Wings Required	Approximate Transport Width*	** Weight
4830-440R	4	40"	160"	132" Rigid	None	11' 1"	3,191 lbs.
4830-530R	5	30"	150"	132" Rigid	None	11' 1"	3,660 lbs.
4830-536R	5	36"	180"	132" Rigid	20" Bolt-On	14' 3"	4,010 lbs.
4830-538R	5	38"	190"	132" Rigid	20" Bolt-On	14' 3"	4,010 lbs.
4830-540R	5	40"	200"	132" Rigid	20" Bolt-On	14' 3"	4,010 lbs.
4830-630R	6	30"	180"	132" Rigid	20" Bolt-On	14' 3"	4,479 lbs.
4830-636R	6	36"	216"	132" Rigid	30" Bolt-On	16' 1"	4,539 lbs.
4830-636F	6	36"	216"	132" Folding	30" Hinged	11' 5"	4,895 lbs.
4830-638F	6	38"	228"	132" Folding	44" Hinged	11' 5"	5,125 lbs.
4830-640F	6	40"	240"	132" Folding	44" Hinged	11' 5"	5,125 lbs.
4830-730R	7	30"	210"	132" Rigid	30" Bolt-On	16' 1"	5,008 lbs.
4830-730F	7	30"	210"	132" Folding	30" Hinged	11' 5"	5,364 lbs.
4830-736F	7	36"	252"	132" Folding	61" Hinged	11' 5"	5,700 lbs.
4830-738F	7	38"	266"	132" Folding	61" Hinged	11' 5"	5,700 lbs.
4830-740F	7	40"	280"	132" Folding	61" Hinged	11' 5"	5,700 lbs.
4830-830F	8	30"	240"	132" Folding	44" Hinged	11' 5"	6,063 lbs.
4830-836F	8	36"	288"	168" Folding	61" Hinged	14' 5"	6,584 lbs.
4830-838F	8	38"	304"	168" Folding	61" Hinged	14' 5"	6,584 lbs.
4830-840F	8	40"	320"	168" Folding	61" Hinged	14' 5"	6,584 lbs.
4830-930F	9	30"	270"	168" Folding	44" Hinged	14' 5"	6,947 lbs.

\* Approximate width to the outside of the frame on machines with bolt-on wings or to the outside of the hinge plate in the folded position on models with hinged wings.

\*\* Weights shown are Units equipped with spring shanks. Units equipped with rigid shanks subtract 200 lbs. per shank.

# SAFETY DECALS

See page P30 for proper location on implement.

**⚠ WARNING**



FAILURE OF HYDRAULIC COMPONENTS OR ACCIDENTAL OPERATION OF HYDRAULIC CONTROLS CAN ALLOW IMPLEMENT OR WINGS TO FALL AND CAUSE SERIOUS BODILY INJURY OR DEATH!

1. Install all maintenance locks when working on or under implement. See operation manual.
2. Keep everyone clear when raising or lowering implement. Check for adequate overhead and side to side clearance before raising or lowering wings. Make certain all hydraulic systems are full of oil and free of air before raising or lowering wings or implement. Check operation manual for detailed instructions.

205-8731 74-102

**⚠ WARNING**

Escaping fluid under pressure can penetrate the skin causing serious injury or death. Relieve pressure before disconnecting hydraulic lines, tighten all connections before applying pressure, and inspect all lines before each use. See "Safety" section in operation manual for additional information.

If an accident occurs, see a doctor immediately. Any fluid injected into the skin must be surgically removed within a few hours or gangrene may result.



205-8735 74-276



74-575 Red Reflective Tape 2" x 9"



74-576 Orange Fluorescent Tape 2" x 9"



74-577 Yellow Reflective Tape 2" x 9"

**⚠ WARNING**

DO NOT OPERATE OR WORK ON THIS MACHINE UNLESS YOU HAVE READ AND UNDERSTAND THE INSTRUCTIONS AND WARNINGS IN THE OPERATION AND MAINTENANCE MANUALS.

FAILURE TO FOLLOW THE INSTRUCTIONS OR HEED THE WARNINGS COULD RESULT IN INJURY OR DEATH. CONTACT YOUR DEALER FOR REPLACEMENT MANUALS.

PROPER CARE IS YOUR RESPONSIBILITY.

205-8740 74-570

**⚠ WARNING**

**UNIT IS TAIL-HEAVY**

The tongue may raise rapidly when unhitching. Lower unit to the ground before unhitching.

A towing unit of insufficient size and weight may result in loss of control. Transport with tractor larger than 150 hp only.

Failure to heed this warning may result in serious bodily injury or death.

205-8739 74-550

**⚠ WARNING**

TO AVOID INJURY DUE TO ACCIDENTAL LOWERING OF IMPLEMENT, MOVE LEVER TO LOCKED POSITION BEFORE TRANSPORTING OR SERVICING IMPLEMENT.

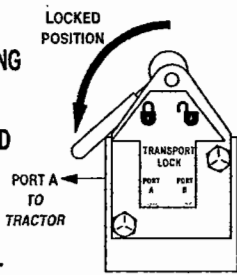

205-8738 74-465

**⚠ WARNING**

AIR TRAPPED INSIDE HYDRAULIC CYLINDERS CAN ALLOW IMPLEMENT OR WINGS TO FALL AND CAUSE SERIOUS BODILY INJURY OR DEATH.

Purge air from hydraulic system by following detailed steps in the Operation Manual.

205-0923 74-113

**This page intentionally left blank.**





# **OPERATING SECTION**

# SAFETY ALERT SYMBOL

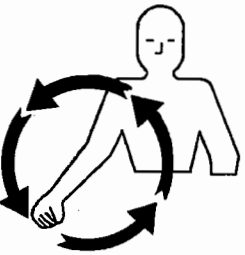
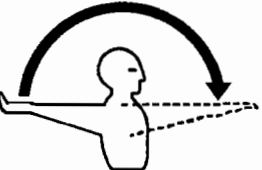
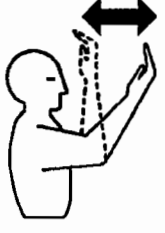
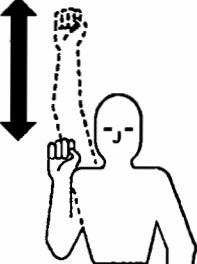
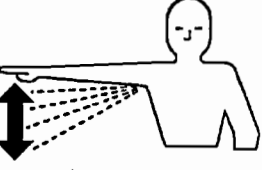

BE ALERT TO THE POSSIBILITY OF PERSONAL INJURY.  
THIS SYMBOL IDENTIFIES IMPORTANT SAFETY MESSAGES.  
CAREFULLY READ THE MESSAGE THAT FOLLOWS.

## TEN MOST COMMON HAND SIGNALS USED IN THE FIELD

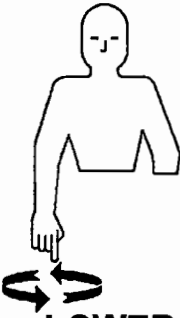
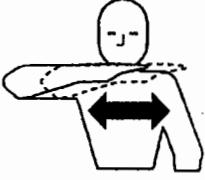
 <p><b>START THE ENGINE</b></p>	 <p><b>MOVE OUT OR TAKE OFF</b></p>	 <p><b>MOVE TOWARD ME</b></p>	 <p><b>SPEED IT UP</b></p>	 <p><b>SLOW IT DOWN</b></p>
 <p><b>THIS FAR TO GO</b></p>	 <p><b>STOP</b></p>	 <p><b>RAISE THE EQUIPMENT</b></p>	 <p><b>LOWER THE EQUIPMENT</b></p>	 <p><b>STOP THE ENGINE</b></p>

# SAFETY FIRST



**WATCH FOR THIS SYMBOL AND CAREFULLY READ THE MESSAGE.**

1. Read and understand the operation manual before operating the machine.
2. Be sure safety decals and reflectors are clean and in place.
3. Do not climb or walk on frames.
4. Never position yourself under any portion of the implement unless the entire unit is lowered to the ground.
5. Stop engine and set parking brake before leaving the operator's position to adjust, lubricate, clean or unclog the machine.
6. Do not stand between the implement and the tractor unless the tractor brakes are locked and the engine is shut off.
7. Never operate unit until hydraulic cylinders and lines are full of oil and free of air.
8. Use a Slow-Moving-Vehicle (SMV) emblem and lights when transporting.
9. Do not road an implement over 15 miles per hour on the best surface conditions. Reduce speed when going up or down hills or when approaching ditches or corners.
10. Make sure there is sufficient ballast on the front of the tractor for safe operation. See "Preparing Tractor For Operation".
11. Make sure the gauge wheels are assembled correctly to prevent possible interference with tractor cab or fenders.
12. Machinery should be operated only by qualified persons familiar to the tractor and equipment, and the safety related items.
13. Keep everyone clear while operating hydraulics or controls and also when machine is in motion.
14. Never permit riders on implement or tractor.
15. Lower parking stand before unhooking.
16. **NEVER** disassemble the spring reset spring assembly. The springs are under compression and have potentially dangerous stored energy. **Disassembly could result in severe personal injury or death.**
17. Spring reset mechanisms operate quickly and forcefully. Use extreme caution when attempting to dislodge an obstruction.
18. Be sure safety signs are clean and readable. All safety related signs must be replaced if the implement is painted or the decals are otherwise rendered unreadable.

Elimination of the hazards listed above should not be construed as providing guarantees that the equipment will meet or exceed all standards or regulations or will be completely safe to all personnel. The operator should inspect and review the implement after it is in his possession for adequacy in safety for the function for which it will be used.

# OPERATING INSTRUCTIONS

Elimination of the hazards listed in this manual should not be construed as providing guarantees that the equipment will meet or exceed all standards or regulations, or will be completely safe to all personnel. The operator should inspect and review the implement after it is in his possession.



**READ ALL THE SAFETY DECALS ON THE IMPLEMENT AND REVIEW THE SAFETY FIRST SUGGESTIONS ON THE BACK OF THIS MANUAL TO REFRESH YOUR MEMORY. WATCH FOR THE SAFETY SYMBOL, AND READ THE INFORMATION. THIS IS FOR YOUR OWN PROTECTION.**

## **ABOUT YOUR IN-LINE RIPPER**

This implement was designed for deep fallow tillage or stubble-mulch tillage with very little residue disturbance. Your ripper will operate over a wide range of speeds, ranging from 4 to 6 miles per hour. Exercise caution in rocky or extremely hard conditions. If rocky conditions exist in your fields, operate at a slow speed and equip your ripper with spring shanks.

Horsepower requirements generally will range from 25 to 35 HP per shank (do not exceed 40 HP per shank).

YOUR RIPPER CAN BE EQUIPPED WITH EITHER A POINT AND LOW DISTURBANCE SHANK CAP OR A POINT AND 5" SHATTERING WING. THE LOW DISTURBANCE SHANK CAP OFFERS THE NARROW PROFILE NEEDED FOR INTER-ROW RIPPING. THE 5" SHATTERING WING WILL OFFER MAXIMUM SUBSOIL FRACTURING BETWEEN SHANKS IN THE COMPACTED ZONE, WHILE MINIMIZING DISTURBANCE OF SURFACE RESIDUE.

## **TILLAGE DEPTH**

As a general rule you should adjust the depth to about one-half inch below the compacted zone. This is normally 7 to 10 inches and very rarely more than 11 inches. Below the compacted zone is soil in its natural virgin state and should not be disturbed. The best fracturing of the zone occurs with the point positioned just below it.

## **PREPARING THE RIPPER FOR OPERATION**

1. Inspect all hardware on the ripper. Make sure nuts and bolts have been tightened properly. See the recommended torque values on back side of colored Assembly Section divider page in this manual. If bolts show signs of wear replace them with the same SAE grade bolt.
2. Before attaching the ripper to tractor, be sure that the hitch pins and spacers are completely assembled to match the tractor.
3. Make sure that all grease zerk locations have been sufficiently greased. **USE EXTREME CAUTION WHEN WORKING AROUND SHARP SUBSOIL POINTS, AND COULTER BLADES.**
4. Check and adjust tightness of wheel bearings and wheel bolts before operation, after the first week, and periodically thereafter.
5. Adjust inflation pressure of tires: 11Lx 15 8-ply tires to 44 PSI, and 20.5 X 8-10 gauge wheel tires to 90 PSI.

## **PREPARING THE TRACTOR FOR OPERATION**

Read your tractor owner's manual. It will describe safe methods of operation. Make sure your tractor has proper added ballast, and that its hydraulic system is full of oil and working properly. Check tractor brakes and warning lights, and make sure that they are in working order.

**IMPORTANT:** THE 3-POINT MOUNTED RIPPER WILL ADD A CONSIDERABLE AMOUNT OF WEIGHT BEHIND THE REAR AXLE OF YOUR TRACTOR. CALCULATE THE WEIGHT OF YOUR MODEL OF RIPPER INCLUDING ALL ACCESSORIES. REFER TO YOUR TRACTOR OWNER'S MANUAL AND DETERMINE THE 3-POINT HITCH LIFT CAPACITY AND THE BALLAST REQUIRED FOR THE FRONT OF YOUR TRACTOR. ADD THE NECESSARY FRONT BALLAST AND CHECK THE INFLATION PRESSURES OF ALL TIRES ON THE TRACTOR BEFORE HITCHING.

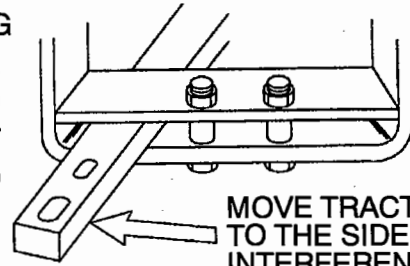

MOVE TRACTOR DRAWBAR TO THE SIDE TO PREVENT INTERFERENCE WHEN COULTER IS MOUNTED IN CENTER.

M4700-5

Set the tractor wheels for the desired spacing so that the wheels are centered between the rows.

## ATTACHING THE RIPPER TO THE TRACTOR

**⚠ Warning:** Do not allow any person to stand between the tractor and the implement while backing into position. Sudden loss of control could cause serious injury or death to a person caught between the tractor and implement. Tell your helper to wait until you give him the signal that the tractor is in park or neutral and that the brake is set and the engine is shut off.

### **Tractor Without Quick Coupler**

Back tractor and position the draft links in front of and in line with hitch pins. Stop engine and set brakes. Extend draft links to enable installation of hitch pins. Install pins and spacer bushings. Secure with klick pins. Adjust length of center link, and pin in place. Raise the unit and raise the tool bar stands.

### **Tractor With Quick Coupler**

Lower coupler to allow jaws to pass under the mast spacer and hitch pins. Back the tractor, raise coupler to firmly seat coupler jaws, then lock latch levers. Be sure the spring-loaded latches in the lower coupler jaws are extended above the hitch pins. Raise the unit and raise the tool bar stands.

## DETACHING THE RIPPER FROM THE TRACTOR

Lower the tool bar stand (see photo to the right), and pin it into place<sup>①</sup> before detaching the unit.

NOTE: Top hole in stand is for shipping purposes, **use the second hole from the top.**

Lower implement onto a level surface. Loosen center link as necessary to remove load from the hitch. Release pressure from center link, and remove pin before removing lower hitch pins.

On Quick Coupler hitches, simply release Quick Coupler latch levers and detach tractor from the unit. Before detaching from wing model rippers:

- Turn tractor off
- Release hydraulic pressure by moving the control levers back and forth
- Disconnect hydraulic hoses

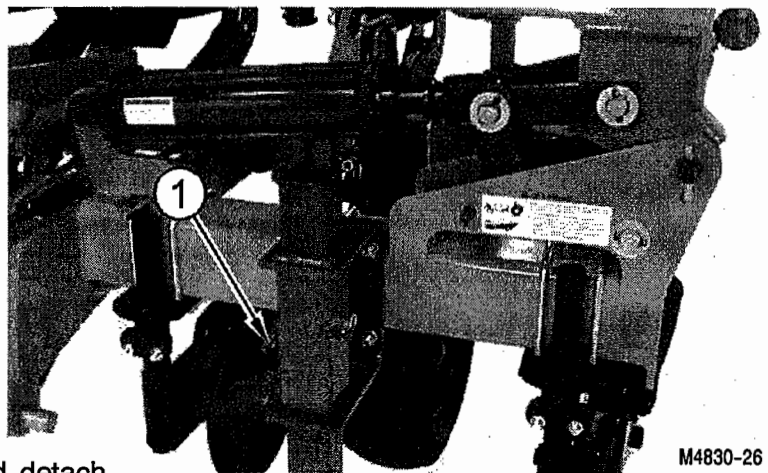

M4830-26

## **OPTIONAL PULL HITCH**

For tractors without three-point hitches, your 4830 In-Line Ripper can be equipped with an optional pull hitch. This allows your unit to be attached to your tractor drawbar.

 **Warning:** The tongue may raise rapidly when unhitching. Lower unit to the ground before unhitching. Failure to heed this warning may result in serious injury or death.

### **Hitching and Unhitching**

 **Warning:** Do not allow any person to stand between the tractor and implement while backing into position. Sudden loss of control could cause serious injury or death to a person caught between the tractor and implement. Tell your helper to wait until you give him the signal that the tractor is in park or neutral and the brake is set and the engine is shut off.

#### **Hitching to the tractor:**

1. The ripper should be lowered to the ground with the weight on the shanks and the tongue should be supported by the jack.
2. Unpin the tractor drawbar so it can be moved from side-to-side.
3. A clevis support pin is provided to support the hitch clevis in a horizontal position while hitching to the unit.
4. Back the tractor to the ripper hitch.
5. Attach the clevis to tractor drawbar with a clevis pin that fits the hole size in the tractor drawbar. Make sure the clevis pin is locked or bolted in place to prevent loss.
6. Fasten the safety chain to the tractor.
7. Remove small clevis support pin and place in storage position in hole in the plate on top of the hitch. Place the tongue jack in its storage location on top of the tongue.
8. Connect the hydraulic hoses and light plug. NOTE: The hose(s) with the red grip(s) is the raise/lower hose.

#### **Unhitching from the tractor:**

If the ripper is not to be used for the remainder of the day, select a good parking place that will permit the lowering of the ripper to the ground.

1. To unhitch the tractor from the ripper, place the tractor in park or neutral and set the brake.
2. Have all personnel stand clear and lower the unit to the ground so that the weight of the unit is resting on the shanks.
3. Turn off tractor power and relieve any hydraulic pressure that might be in the system by moving the tractor control lever(s) back and forth.
4. Remove the tongue jack from its storage location and raise the tongue height until the clevis pin can be removed.
5. Disconnect the hydraulic hoses and light plug; the tractor may be moved away.

## **TRANSPORTING**

**NOTE: An SMV emblem and a light kit were furnished as standard equipment with your implement. Make sure they are in place, clean and in working order.**

Use the ASAE Slow Moving Vehicle (SMV) emblem. The emblem is mounted point up in a plane perpendicular to the direction of travel  $\pm 10^\circ$ . It shall be placed centrally at the rear of the vehicle, unobscured, and 2' to 6' (0.61 to 1.8m) above the ground, measured from the lower edge of the emblem. The SMV emblem should be wiped clean before entering the road or highways. Comply with state and local laws pertaining to lighting and road widths. Turn on flashing lights whenever traveling on a highway except where prohibited by law. If the implement obscures the tractor warning lamp, a lamp must be added to the left of the implement. Transport during daylight hours only. Watch your clearance. Be aware of any obstacles along the side of the roadway that might be caught by the ripper when passing by. Pull over to the side of the road to permit safe clearance for oncoming traffic. Keep the red, orange and yellow reflectors clean and visible. Replace the reflectors if they become faded or damaged. Watch for any pedestrians on the side of the road that need to be warned of your presence.

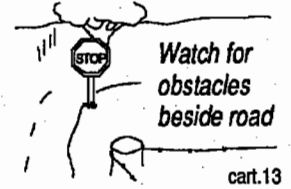

- ⚠ Warning:** Always check conditions of 3-Point hitch pins and bolts before transporting the implement. Do not road implement over 15 m.p.h. on the best surface conditions. Reduce speed when going up or down hills or when approaching ditches or corners. Serious injury or death may result from loss of control of the tractor.

### **Transporting With Pull Hitch**

Follow the same rules as the mounted ripper when transporting the ripper with the pull hitch with these additional instructions:

1. A safety chain is furnished as standard equipment with the pull hitch.

**⚠ Warning:** Always use a safety chain with a tensile strength equal to the gross weight of the unit, plus any attachments, when transporting. Serious injury or death may occur from loss of control of the unit.

2. Always check the tire pressure before transporting and look for damaged tires. Wobble the tires from side-to side. If excessive play is noted, adjust the hub spindle nut before transporting to prevent damage to the hub or bearings.

**⚠ Warning:** When equipped with the pull hitch, the unit is considerably tall heavy. Only transport the unit with a tractor with 150 or greater horsepower. Transporting with another vehicle could result in loss of control resulting in serious injury or death.

3. Move the lever on the transport lock valve located near the tongue hose stand to the LOCKED position.

**⚠ Warning:** Lock the wheel transport lock valve before transporting to prevent injury or death due to accidental lowering of implement.

### **Raising the Wings**

The ripper should be in raised position to fold the wings. Remove the wing lock down pins at each hinge and place in the storage location hole in the hinge plates. Clear the area of personnel and engage the hydraulics to fold.

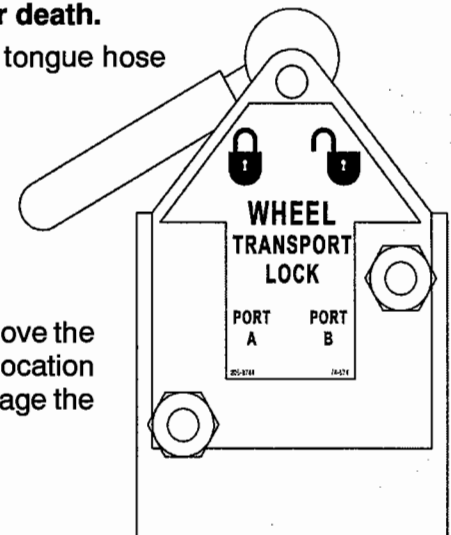

M4830-29

## Lowering the Wings

Check the area to be sure it is clear to lower the wings. With the ripper in the raised position, engage the hydraulics to lower the wings. Remove the wing lock down pins from their storage position and lock down the wings.

## Depth Adjustment

1. Lower the implement to the ground.  
NOTE: Raising the gauge wheel will increase the ripping depth.
2. Turn handle (4) in order to raise or lower the gauge wheel. See photo at right.  
NOTE: The gauge wheels should be adjusted to the same depth.
3. Repeat Step 2 for the other gauge wheel.

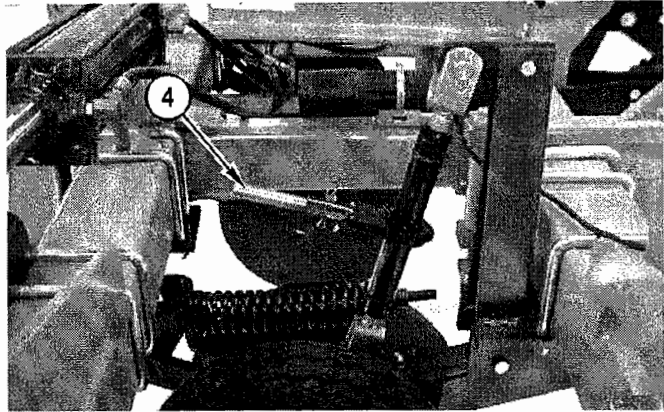

M4830-27

## Coulter Adjustment

NOTE: For the best performance of the shanks, the coulters must be aligned with the shanks.  
Tab (6) limits the movement of the coulter arm. Turn the coulter shaft to a position that will not allow the coulter to contact the gauge wheels.

1. Loosen nuts (5) in order to raise or lower the coulter.

NOTE: Adjust all of the coulters to the same depth.

2. Position tab (6) and tighten nuts (5).

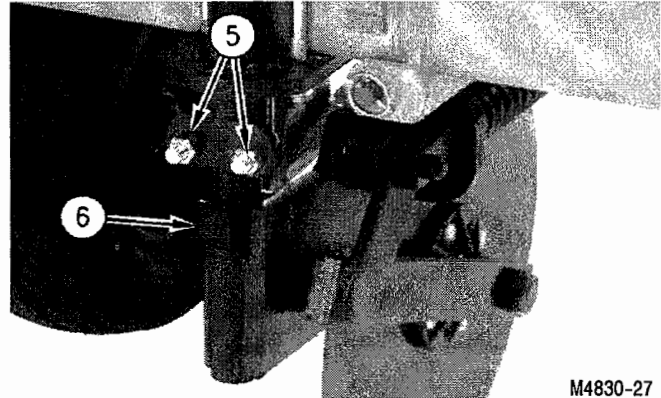

M4830-27

## Pull Hitch Adjustment

Adjust the center turnbuckle longer or shorter so that the unit is running level in field position.

Stroke control stops are provided to adjust the depth of the transport wheel in field position. Stops are stored on a rod along the left side of the tongue. Place the stroke control stops on the rod of the left wheel cylinder (4-1/4" x 10") only. This will control both wheel cylinders.

## No-Till Attachment

The no-till wheels may be adjusted by the user in a variety of ways to achieve the desired field finish. They may be adjusted right to left to be closer or farther from the side of the shank. The depth and spring down pressure may be increased or decreased for more or less firming of the soil. The wheels may be angled from front to rear, however, the tire works best in the straight forward position in most cases.

NOTE: For the best performance of the shank and no-till wheels the coulters must be aligned with the shanks.

With varying conditions and point arrangements the shank path can be wide or narrow. Adjust the wheels farther apart for the wider path to firm the soil and close the shank path.

Adjust the wheels closer for the narrow shank path. To move the wheels closer or farther apart, loosen the 1/2" carriage bolts (1) at the top of the wheel arm and slide the wheels in or out. Loosening these bolts also allows the wheels to be angled front to rear. A recommended starting point is 7" between the inside of the wheels.

To adjust the depth and down pressure, loosen the two 1/2" bolts (2) on the side of the closing wheel brackets. Push the wheel assembly forward in the slots to raise or lower the wheel. Lower the wheel to maintain ground contact at shallower shank depths or to add more spring pressure. Raise the wheel for deeper shank depths or less spring pressure. Pull the assembly to the rear to seat the bolt in a notch and tighten the bolts. It is recommended that the flat spring be approximately 1" off the stop during operation as a starting point. (See illustration)

**DO NOT** adjust the wheels so that the **spring up stop** will hit during normal operation. This will not allow enough free travel and damage to the assembly may occur.

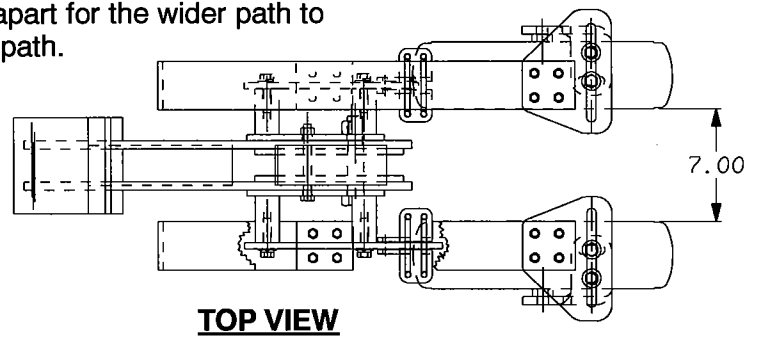

**TOP VIEW**

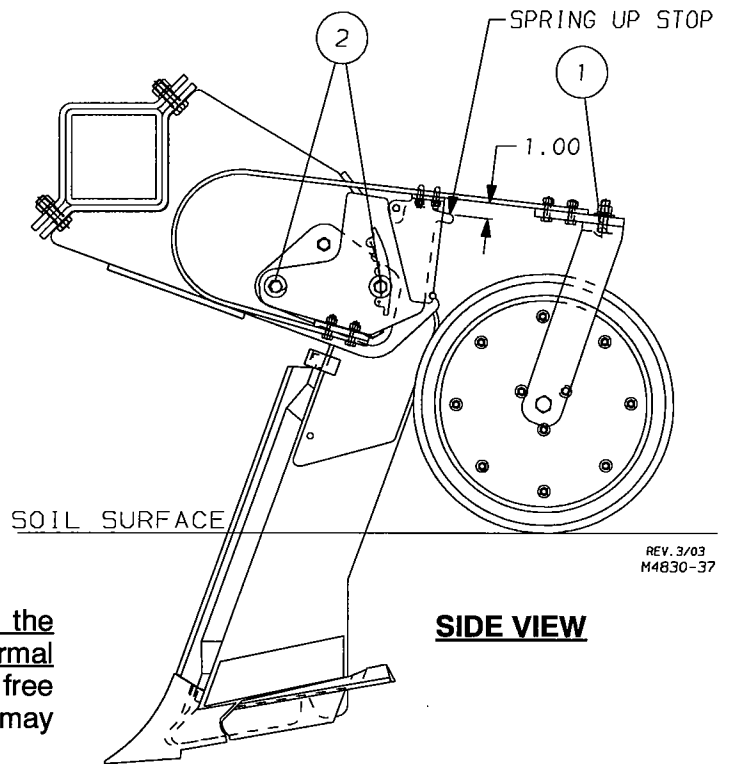

**SIDE VIEW**

REV. 3/03  
M4830-37

## **HYDRAULIC SAFETY FOR WING MODEL RIPPER PLEASE READ CAREFULLY**

### **PURGING HYDRAULIC SYSTEM:**

If the implement hydraulic system has never been used, stored over a period of time or disassembled for any reason, unpin the rod ends of the cylinders and support the cylinders so the rod ends will clear frame members when fully extended. Back the tractor to the front of the implement and connect the hydraulic hoses. Check the tractor hydraulic reservoir and make sure it is full of the manufacturer's recommended oil. If you are sure the implement hydraulic hose connections are tight, begin filling the system by extending and retracting the cylinders. Hold the control lever open and pause at the end of each stroke to purge the air from the system. Continue the cycles until the cylinders respond with immediate solid actuation. When you are sure the systems are free of air, pin the rod ends of the cylinders to the implement cylinder lugs.



**Warning:** Escaping fluid under pressure can penetrate the skin causing serious injury or death. Avoid the hazard by relieving pressure before disconnecting hydraulic lines. Tighten all connections before applying pressure.

Search for leaks with a piece of cardboard. Protect hands and body from high pressure fluids.

If an accident occurs, see a doctor immediately. Any fluid injected into the skin must be surgically removed within a few hours or gangrene may result.

## **AVOID HEATING NEAR PRESSURIZED HYDRAULIC HOSES**

Flammable spray can be generated by heating near pressurized hydraulic hoses, resulting in severe burns to yourself and bystanders. Do not heat by welding, or using a torch near hoses. Hose can be accidentally cut when heat goes beyond the immediate flame area.

### **THE FOLLOWING WARNINGS PERTAIN TO THE MORE COMMON ABUSES OF HYDRAULIC HOSE:**

- |  |   |
|--|---|
| 1. <b>INSPECT</b> the hose assembly before each use.   | 3. <b>DO NOT EXCEED</b> the maximum recommended working pressure of the hose.   |
| 2. <b>REPLACE</b> the hose assembly immediately if:<br>A. The jacket of the hose appears abnormal.<br>B. You have reason to believe it may be abnormal.<br>C. There is any fluid leakage.<br>D. The couplings are damaged.<br>E. The hose is damaged or kinked.<br>F. The reinforcement is visible through the jacket. | 4. <b>DO NOT KINK</b> the hose assembly.<br>5. <b>DO NOT BEND</b> the hose assembly beyond its minimum bend radius of 3.25 inches.<br>6. <b>DO NOT EXPOSE</b> to temperatures in excess of 225° Fahrenheit<br>7. <b>DO NOT USE AS A STRENGTH MEMBER</b> for pulling or lifting equipment. |

**Warning:** If replacing hydraulic hose, use only hose that meets or exceeds 3,000 PSI working pressure. Serious injury or death may occur if a hose ruptures.

**IMPORTANT: REPAIR OF HYDRAULIC CYLINDERS SHOULD BE MADE BY AN AUTHORIZED KRAUSE DEALER.**

Prevent damage to trail hoses by supporting them from the tractor with an elastic strap "A". Avoid having excess hose between the implement support "B" and the tractor connection "C". Either reposition the hose farther back on the implement or request a shorter hose from your dealer.

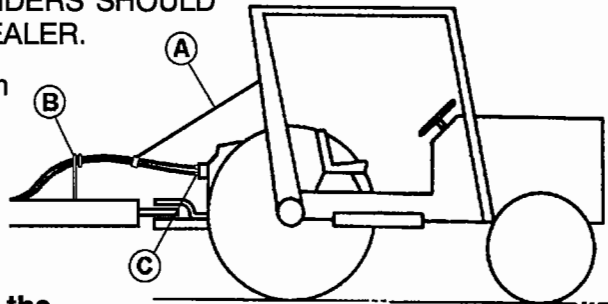

**Warning:** Air in the hydraulic system will allow the wings to drop suddenly which could result in serious injury or death.

## **FERTILIZER EQUIPMENT**

Contact Krause for information and referrals.

## **SERVICING**

All maintenance should be performed with the unit either lowered to the ground or supported on suitable stands. The tractor should be in park, the brake set, and the engine turned off.

On units equipped with a pull hitch the unit may be locked up for service by moving the lever on the wheel transport lock valve located near the tongue hose stand to the LOCKED position and installing the maintenance locks located on the wheel mounts on the transport wheel cylinders before working on or around the unit. The tractor should be in park, the brake set, and the engine turned off.

**Warning:** Unit is considerably tail-heavy in this position and must remain hitched to the tractor when the maintenance locks are in place to prevent the unit from tipping backwards. Failure to do so could cause serious injury or death.

## **General Maintenance**

All bolts should be checked and tightened after the first half day of operation and periodically thereafter.

Check points, shank caps and coulter blades at the end of each day and replace worn parts as needed.

**Caution:** Coulters blades are very sharp, to prevent injury, use extreme caution when replacing or working around coulters blades.

## Wheel Bearings

Grease wheel bearings every 50 hours of use. Check for excessive end play each time that the bearings are greased. Once a year, clean and repack the wheel bearings with EP#2 Grease. Replace seals each time that the bearings are removed. Replace any worn or damaged parts. Use light oil on the seal surface and use extreme care when pushing seal over the spindle. Install outer bearings, flat washer, and slotted nut. Tighten nut while turning hub until there is resistance to rotation. Then back off nut 1 to 2 slots until hub turns freely without end play. Secure nut with clinched cotter pin.

## Coulter Hubs

Follow the same procedure for servicing the coulter hubs as with the Wheel Bearings with this exception. When replacing the slotted nut, tighten the nut while turning hub until it is snug then turn to the next hole to secure the nut with the clinched cotter pin. The coulter should turn freely with no wobble in the blade.

## Grease Points

Every 50 hours of Service or Weekly: Gauge wheel hubs, coulter hubs, pull hitch wheel hubs, and hinges on folding frames.

Every 10 hours of Service or Daily: Coulter pivot, spring shank guide and pull hitch wheel arm pivot.

Yearly: Ratchet Jack

Maintenance should be done whenever possible, with the ripper lowered to the ground.

Follow this procedure when changing points:

- Unfold the wings (if so equipped).
- Raise implement approximately 6" above the ground.
- Place stands under each end of the rear frame bar.
- Put tractor in park position, set brake, turn off engine and block tires to prevent the tractor from rolling.
- Change points from a position behind the shank, not under it.

**Warning:** Make sure that the frame is supported by stands, the tractor is in park, the brake has been set, and the engine turned off before attempting to change points. Serious injury or death may occur from being crushed by the unit.

**Warning:** DO NOT ATTEMPT TO DISASSEMBLE THE SPRING ASSEMBLY. THE SPRING IS PRE-LOADED INTO THIS POSITION AND WILL REACT VIOLENTLY IF RELEASED. SERIOUS BODILY INJURY OR DEATH COULD RESULT.

**NO individual repair parts are available for the spring assembly.**

## REPAIR PARTS

It is recommended that Krause replacement parts be used. KRAUSE PARTS WERE DEVELOPED AND TESTED FOR YOUR MACHINE.

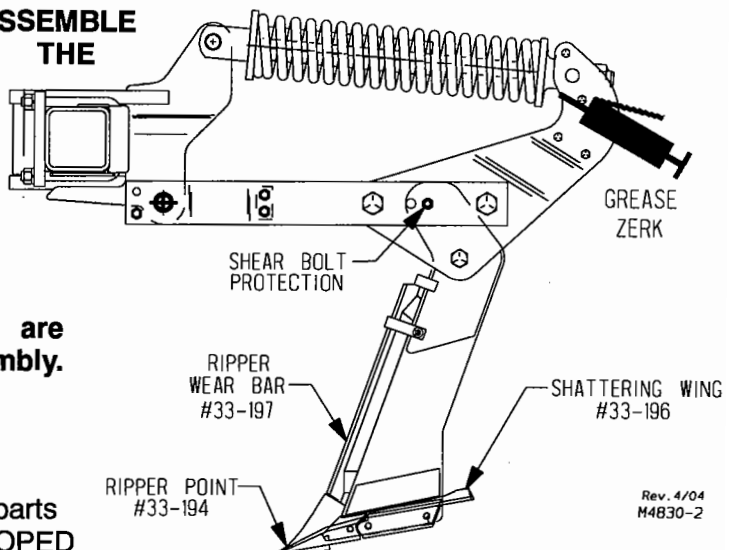

Rev. 4/04  
M4830-2

**⚠ Warning:** If replacing hydraulic hose, use only hose that meets or exceeds 3,000 PSI working pressure. Serious injury or death may occur if a hose ruptures.

IMPORTANT: REPAIR OF HYDRAULIC CYLINDERS SHOULD BE MADE BY AN AUTHORIZED KRAUSE DEALER.

**⚠ Warning:** Explosive separation of a tire and rim parts can cause serious injury or death.

Always maintain the correct tire pressure. Do not inflate the tires above the recommended pressure.

Inflate 20.5 X 8-10 tire to 90 PSI, and 11L x 15 8-ply tires to 44 PSI.

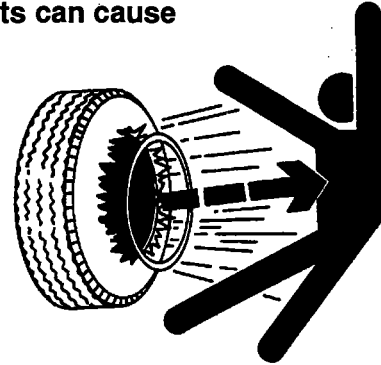

### SUGGESTED REMEDIES TO FIELD PROBLEMS

PROBLEM	POSSIBLE CAUSE	SUGGESTED REMEDY
PLUGGING AROUND SHANKS	Coulters running too deep	Reduce depth to around 3-1/2"
	Coulters running too shallow	If soil is loose or very wet it may be necessary to increase to maximum depth of 4-1/2"
	Coulters not directly in front of shank	Align coulters to shank
NOT LEVEL FRONT TO REAR	Top link of three point hitch out of adjustment	Adjust top link
UNIT WANTS TO PULL TO ONE SIDE	Gauge wheels out of adjustment	Make sure gauge wheels are set to the same depth
	Bent shank	Straighten or replace
	Bolt sheared in shank	Replace shear bolt
COVERING TOO MUCH RESIDUE	Coulters too shallow	Readjust to around 3-1/2" depth
	Pulling unit too fast	Slow down
	Shanks set too shallow	Readjust depth
POOR PENETRATION	Not level front to rear	Adjust top link
	Broken point	Replace
	Coulters set too deep	Reduce depth to around 3-1/2"
EXCESSIVE DAMAGE TO COULTER BLADES AND POINTS	Heavy rock conditions	Reduce speed
		Reduce coulter depth
	Frozen ground	Try to avoid
<b>★ ATTENTION: DO NOT REMOVE SHANKS</b>		
★ NOTE: Removing shanks to obtain additional depth will cause the remaining shanks and frame members on which these shanks are mounted, to be overloaded. This could cause bent shanks or broken bolts or clamps.		
Excessive point wear may cause point to fall off shank. Running machine without a point will quickly cause tip of shank to wear. When shank becomes worn, a new point will not stay on shank and will continue to fall off.		
Do not operate machine without a point. If tip of shank becomes worn, shank must be replaced or rebuilt.		

# **PARTS SECTION**

THE FOLLOWING ILLUSTRATED PARTS SECTION HAS BEEN COMPILED TO REFLECT PART NUMBERS REQUIRED TO ORDER PARTS, AND TO SUPPORT THE ASSEMBLY SECTION FOR DIMENSIONS AND DESCRIPTIONS OF ALL PARTS, BOLTS, PINS, ETC. THE OPERATOR CAN ALSO IDENTIFY PART NAMES TO CLARIFY PROPER OPERATIONAL STEPS.



# RIGID FRAME

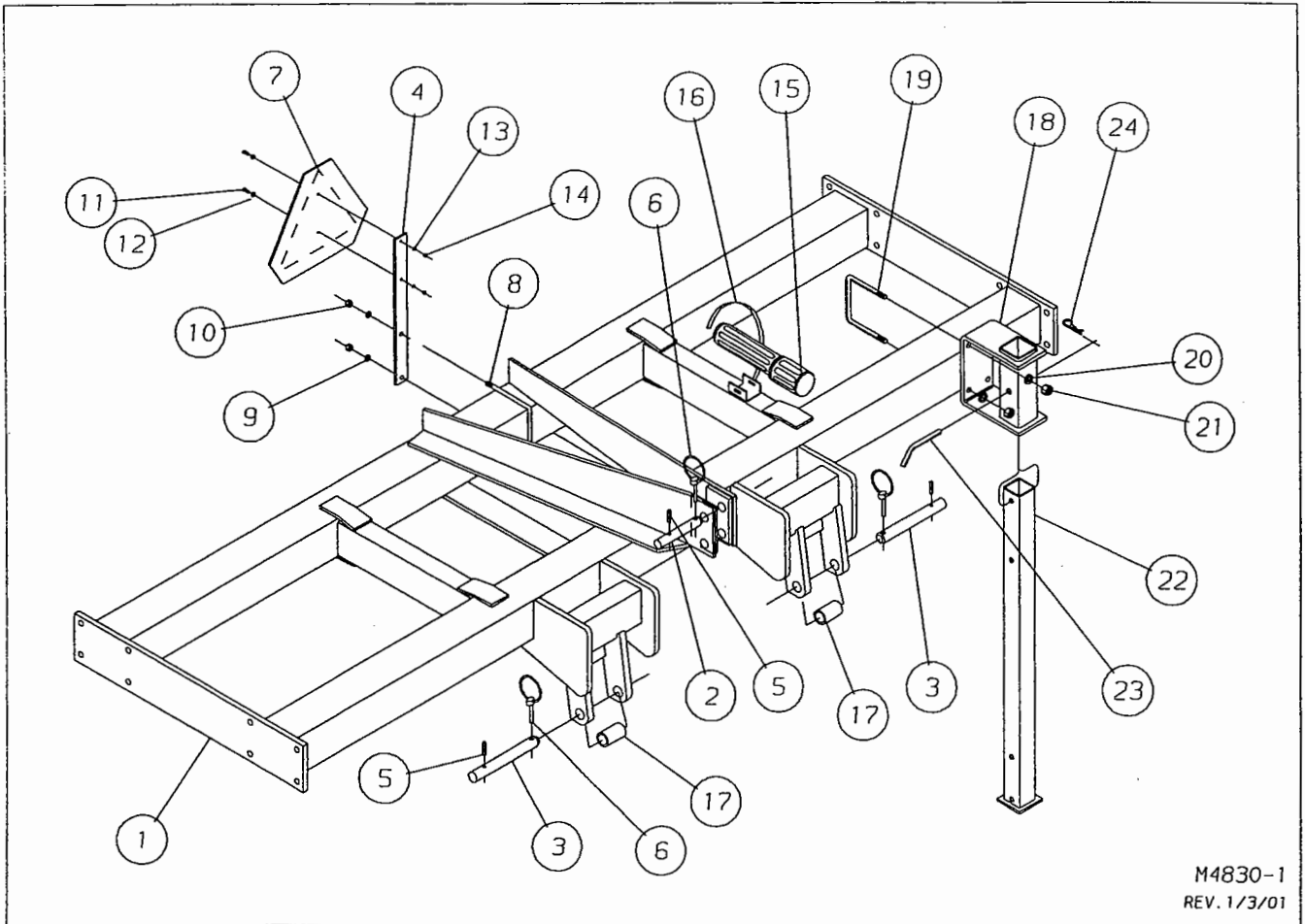

M4830-1  
REV. 1/3/01

## FOR MODELS - ALL RIGID

4/01

Item	Part Number	Part Description	Qty.
1	4830-2-0	Rigid Frame (132-1/2")	1
2	4830-0-5	Upper Link Pin	1
3	4830-0-4	Lower Link Pin	2
4	4830-0-7	SMV Bar	1
5	60-615	3/8" DIA. x 2" Roll Pin	3
6	60-102	Klick Pin	3
7	74-487	SMV Sign	1
8	61-268	1/2" DIA. U-Bolt	1
9	64-107	1/2" STD. Lock Washer	2
10	63-106	1/2NC Hex Nut	2
11	62-417	1/4NC x 1" GD5 Cap Screw	2
12	64-101	1/4" STD. Flat Washer	2
13	64-100	1/4" STD. Lock Washer	2
14	63-100	1/4NC Hex Nut	2
15	99-218	Owner's Manual Storage Canister - Black	1
16	25-1163	Hose Clamp	1
17	4830-0-8	Cat. 3 Spacer Bushing	2
18	4830-59-0A	Stand Bracket	2
19	61-261	5/8" DIA. U-Bolt	4
20	64-109	5/8" STD. Lock Washer	8
21	63-109	5/8NC Hex Nut	8
22	4830-58-0	Stand Weldment	2
23	4600-0-28	Stand Pin	2
24	60-716	#3 Hair Pin Cotter	2

# FOLDING FRAME

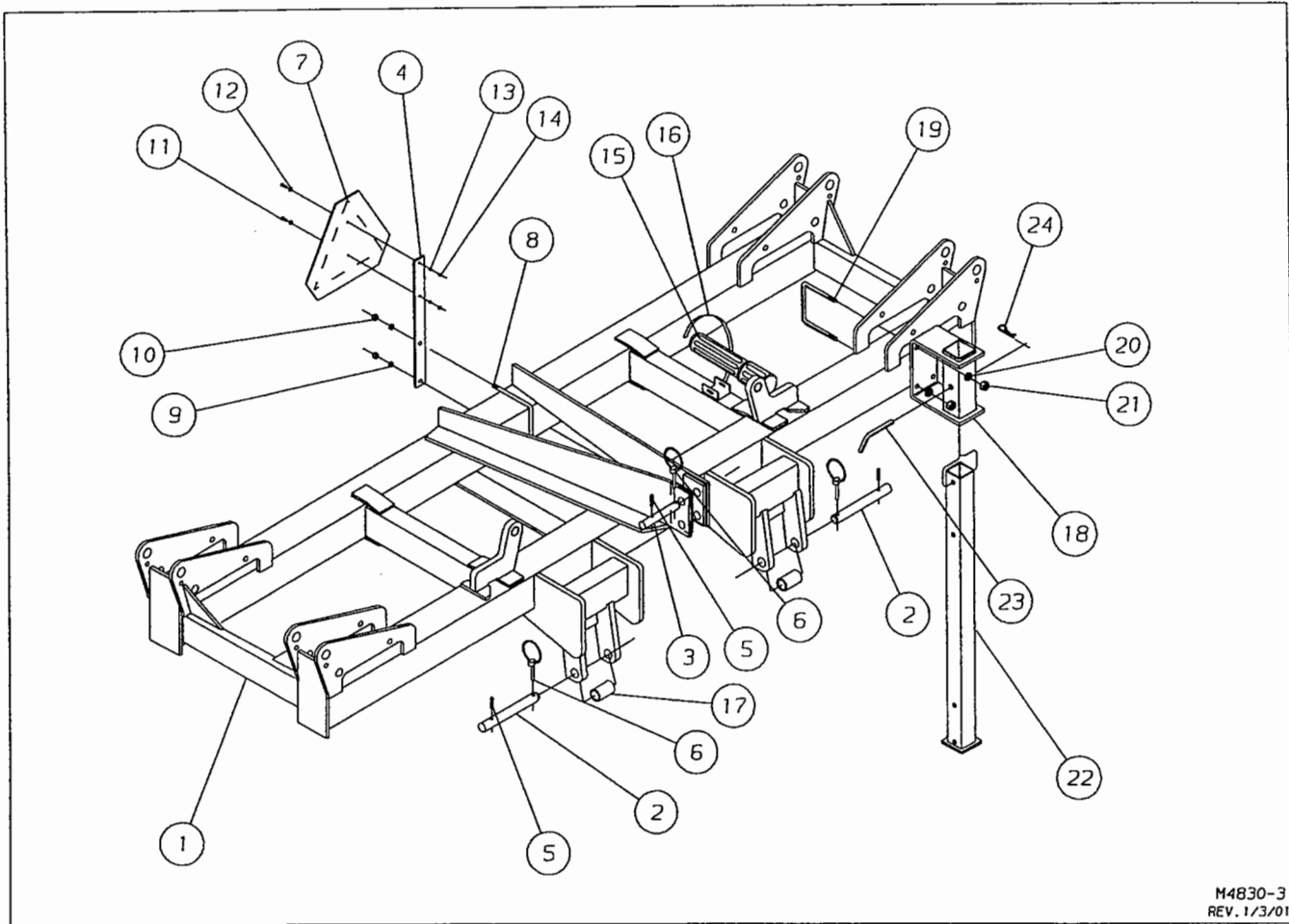

M4830-3  
REV. 1/3/01

## FOR MODELS - 6 and 7 Shank Folding, 830F

4/04

Item	Part Number	Part Description	Qty.
1	4830-300-0	132" Folding Frame	1
2	4830-0-4	Lower Link Pin	2
3	4830-0-5	Upper Link Pin	1
4	4830-0-7	SMV Bar	1
5	60-615	3/8" DIA. x 2" Roll Pin	3
6	60-102	Klick Pin	3
7	74-487	SMV Sign	1
8	61-268	1/2" DIA. U-Bolt	1
9	64-107	1/2" STD. Lock Washer	2
10	63-106	1/2NC Hex Nut	2
11	62-417	1/4NC x 1" GD5 Cap Screw	2
12	64-101	1/4" STD. Flat Washer	2
13	64-100	1/4" STD. Lock Washer	2
14	63-100	1/4NC Hex Nut	2
15	99-218	Owner's Manual Storage Canister - Black	1
16	25-1163	Hose Clamp	1
17	4830-0-8	Cat. 3 Spacer Bushing	2
18	4830-59-0A	Stand Bracket	2
19	61-261	5/8" DIA. U-Bolt	4
20	64-109	5/8" STD. Lock Washer	8
21	63-109	5/8NC Hex Nut	8
22	4830-58-0	Stand Weldment	2
23	4600-0-28	Stand Pin	2
24	60-716	#3 Hair Pin Cotter	2

# FOLDING FRAME

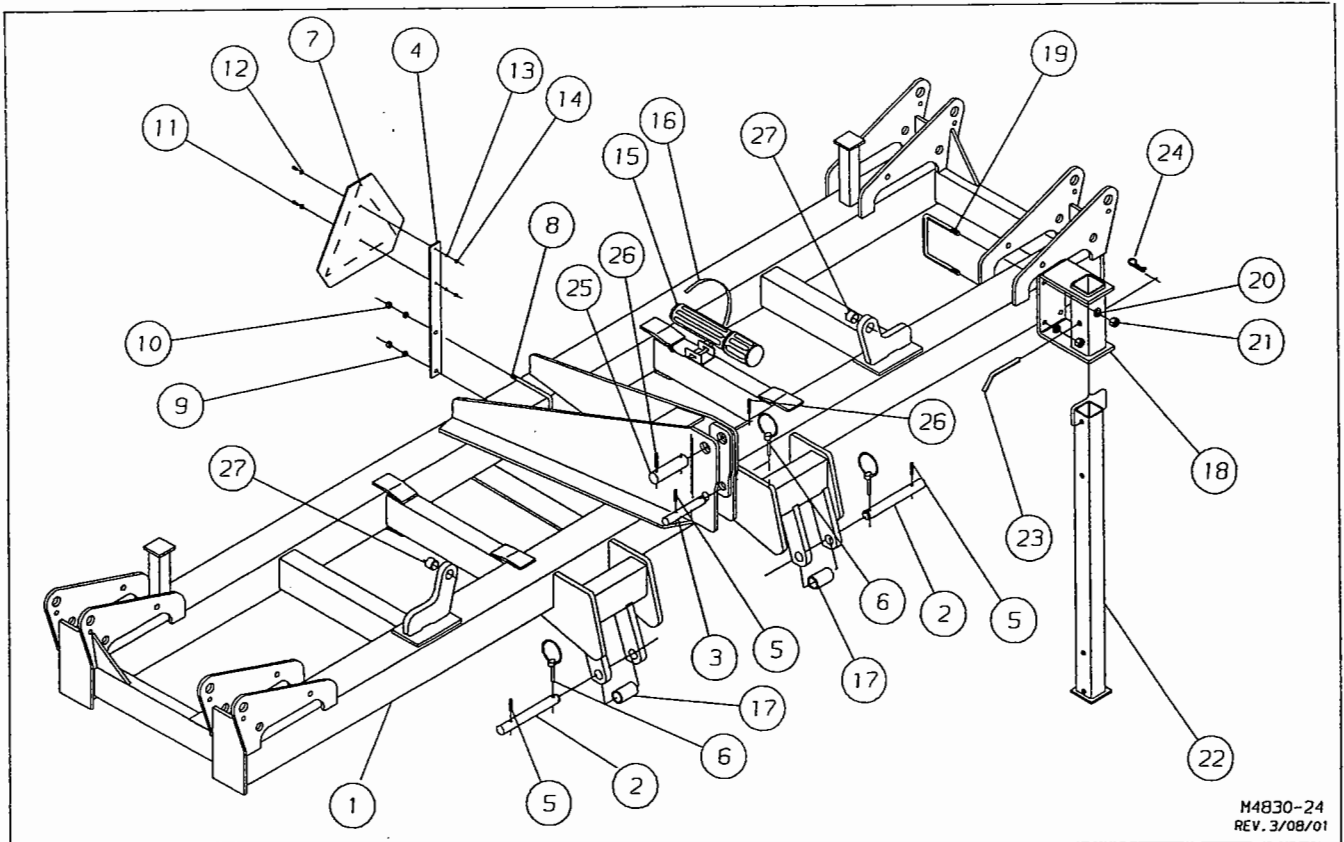

M4830-24  
REV. 3/08/01

## FOR MODELS - 836F, 838F, 840F & 930F

4/04

Item	Part Number	Part Description	Qty.
1	4830-400-0	168" Folding Frame - Shown	1
2	4830-0-4	Lower Link Pin	2
3	4830-0-5	Upper Link Pin	1
4	4830-0-7	SMV Bar	1
5	60-615	3/8" DIA. x 2" Roll Pin	3
6	60-102	Klick Pin	3
7	74-487	SMV Sign	1
8	61-268	1/2" DIA. U-Bolt	1
9	64-107	1/2" STD. Lock Washer	2
10	63-106	1/2NC Hex Nut	2
11	62-417	1/4NC x 1" GD5 Cap Screw	2
12	64-101	1/4" STD. Flat Washer	2
13	64-100	1/4" STD. Lock Washer	2
14	63-100	1/4NC Hex Nut	2
15	99-218	Owner's Manual Storage Canister - Black	1
16	25-1163	Hose Clamp	1
17	4830-0-8	Category 3 Spacer Bushing	2
	4830-0-13	Category 4 Bushing	2
18	4830-59-0A	Stand Bracket	2
19	61-261	5/8" DIA. U-Bolt	4
20	64-109	5/8" STD. Lock Washer	8
21	63-109	5/8NC Hex Nut	8
22	4830-58-0	Stand Weldment	2
23	4600-0-28	Stand Pin	2
24	60-716	#3 Hair Pin Cotter	2
25	4830-0-14	Upper Pin, Category 4	1
26	60-617	3/8" x 2-1/2" Roll Pin	2
27	53-101	Wear Sleeve	2

# RIGID WING FRAMES & FOLDING WING FRAMES

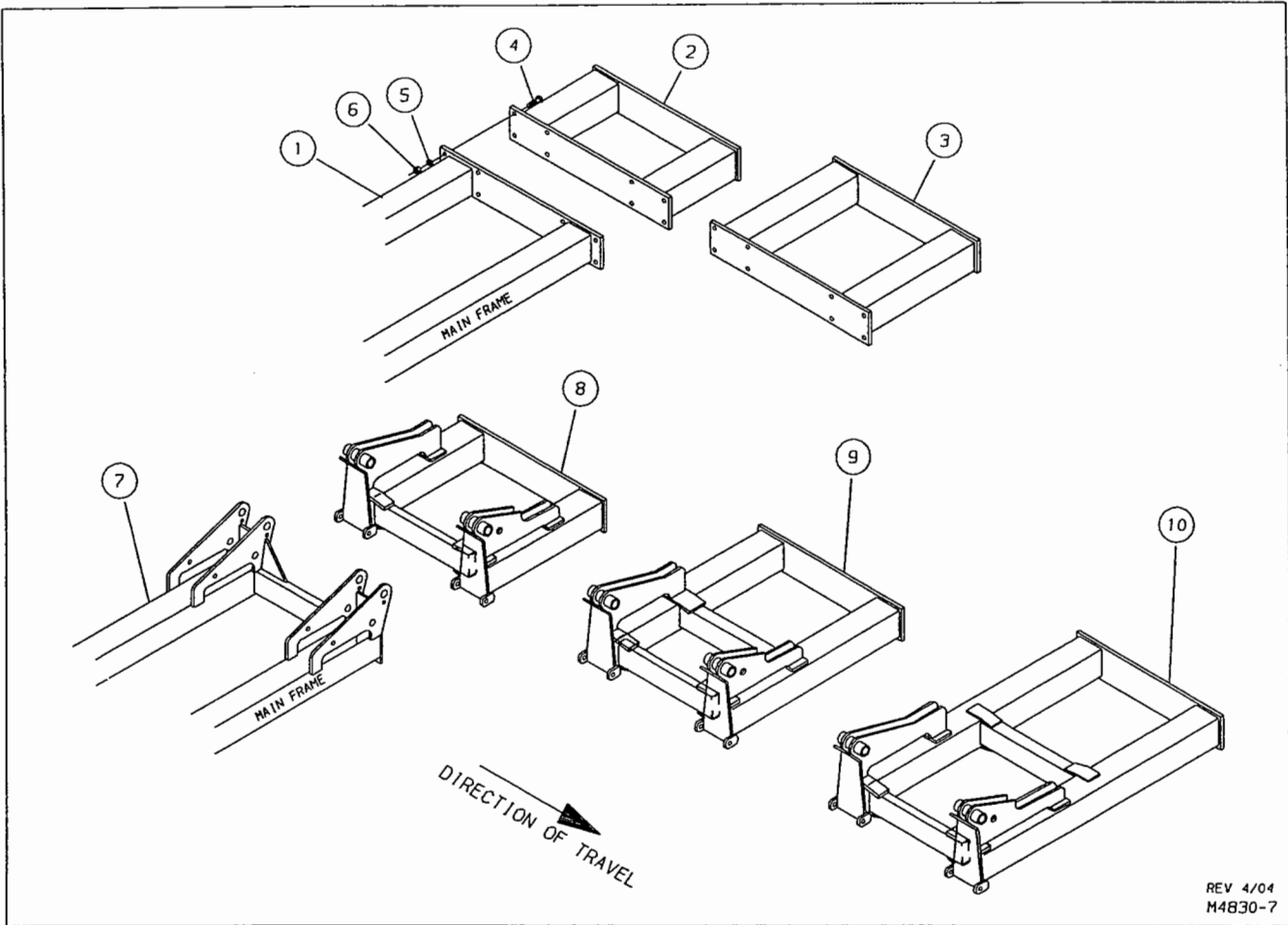

## FOR MODELS - ALL FOLDING

4/04

Item	Part Number	Part Description	Qty.
1		Rigid Frame	1
2	4830-17-0	Rigid Wing Frame (20")	2
3	4830-18-0	Rigid Wing Frame (30")	2
4	62-195	3/4NC x 2-1/2" GD5 Cap Screw	16
5	64-112	3/4" STD. Lock Washer	16
6	63-112	3/4NC Hex Nut	16
7		Folding Frame	1
8	4830-301-0	Left Folding Wing Frame (30")	1
	4830-302-0	Right Folding Wing Frame (30")	1
9	4830-303-0	Left Folding Wing Frame (44")	1
	4830-304-0	Right Folding Wing Frame (44") Not Shown	1
10	4830-305-0	Left Folding Wing Frame (61")	1
	4830-306-0	Right Folding Wing Frame (61") Not Shown	1

# WING FOLD ASSEMBLY

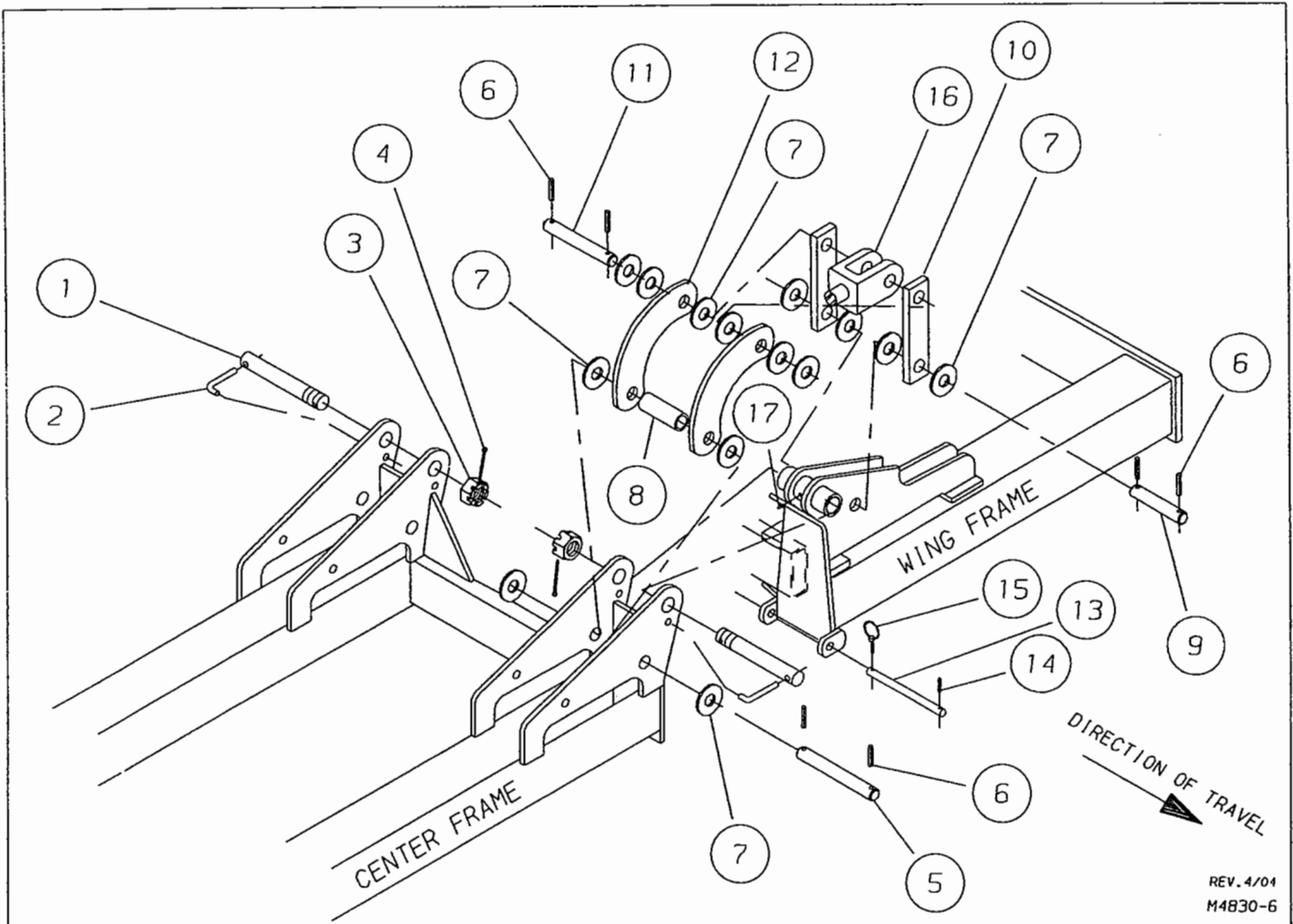

REV. 4/04  
M4830-6

## FOR MODELS - ALL

4/01

Item	Part Number	Part Description	Qty.
1	4830-0-3	Hinge Pin	4
2	1901-0-2	Hinge Pin Lock	4
3	63-128	1-1/2NC Slotted Hex Nut	4
4	60-711	1/4"DIA. x 3" Cotter Pin	4
5	4830-0-2	1-1/4"DIA. x 8-7/8" Fold Link Pin	2
6	60-615	3/8"DIA. x 2" Roll Pin	12
7	64-127	1-1/4" SAE Flat Washer	28
8	4830-0-1	Spacer Tube	2
9	5660-0-7	1-1/4"DIA. x 6-1/4" Pin	2
10	5660-0-6	Hinge Strap	4
11	5660-0-8	1-1/4" DIA. x 8" Hinge Pin	2
12	5660-0-11	Curved Link	4
13	4830-0-6	Fold Lock Pin	4
14	60-605	1/4" DIA. x 1-1/2" Roll Pin	4
15	60-120	3/16" DIA. Klick Pin	4
16	21-171	4" x 16" Hydraulic Cylinder Assembly	2
17	65-110	1/8" Spindrive Zerk	4

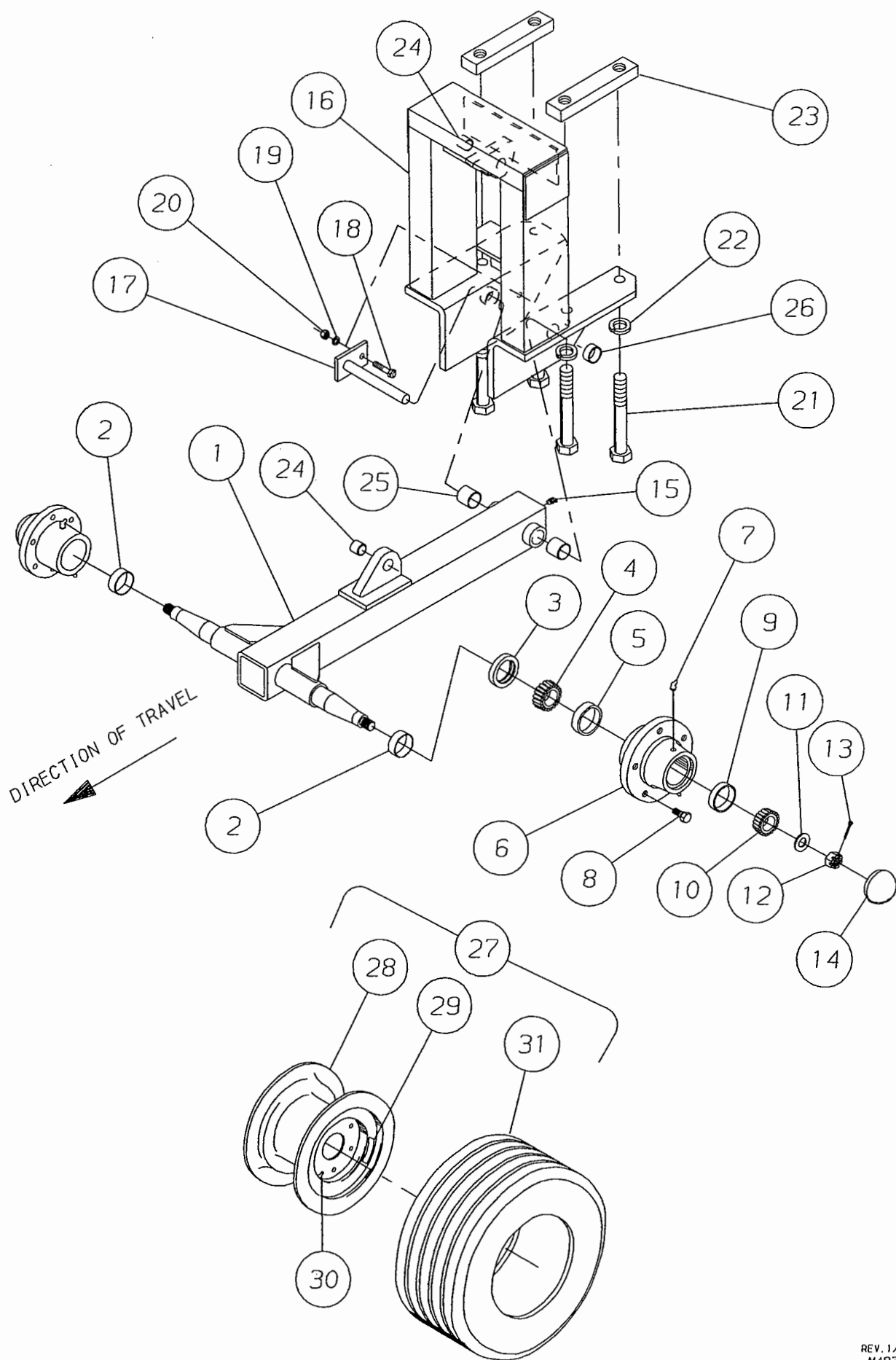

REV. 1/31/01  
M4830-10



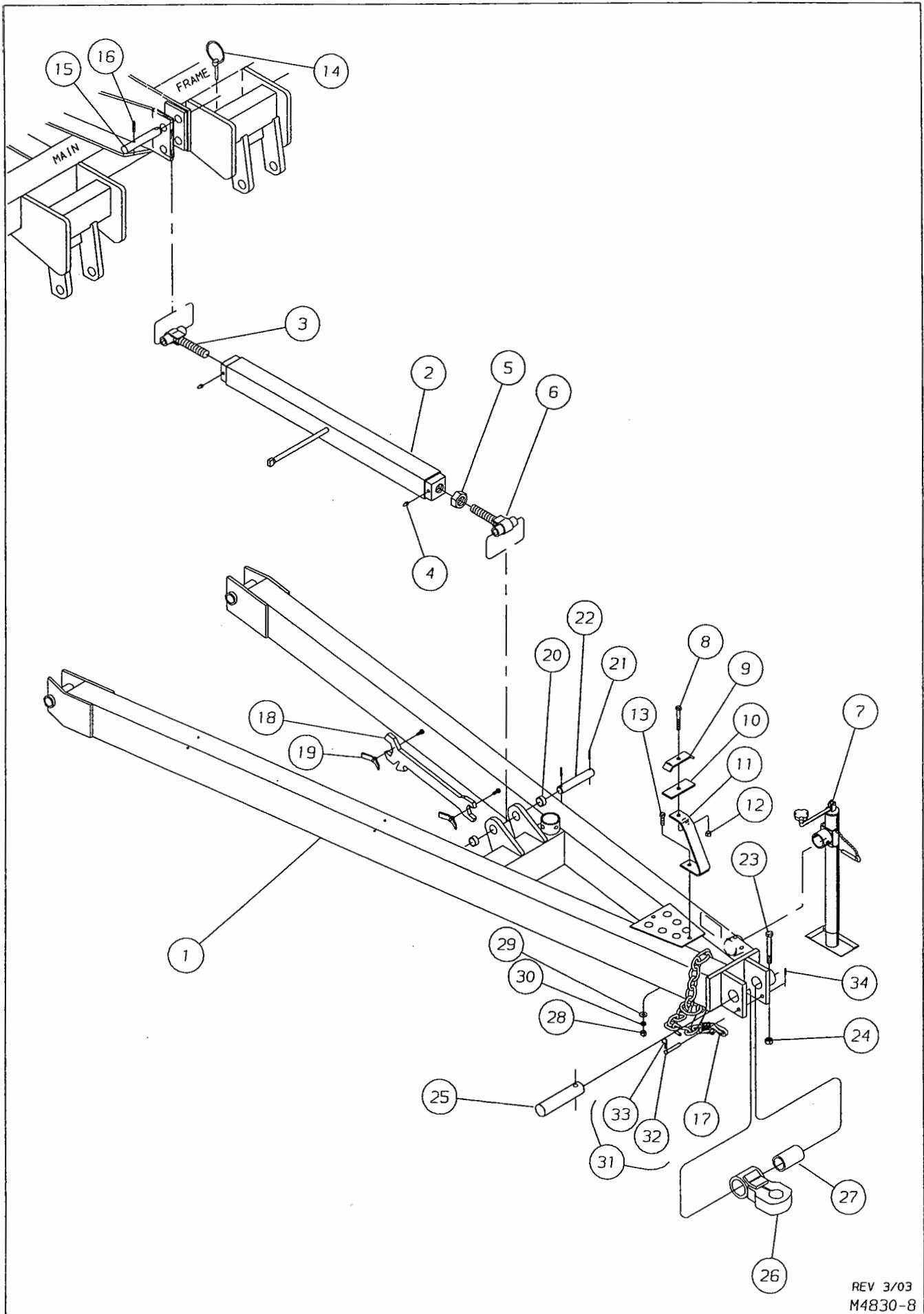

REV 3/03  
M4830-8

# PULL HITCH

**FOR MODELS - ALL**

3/03

Item	Part Number	Part Description	Qty.
1	4830-30-0	Hitch Weldment	1
2	4830-35-0	Turnbuckle Weldment	1
3	4830-34-0	Left Hand Threaded End	1
4	65-114	1/4" Drive Zerk	2
5	63-129	1-1/2NC Hex Jam Nut	1
6	6142-82-0	Right Hand Threaded End	1
7	73-100	Jack	1
8	62-343	1/2NC x 2" GD5 Cap Screw	1
9	2426-170-5	Hose Clamp	1
10	2145-170-5	Hose Plate	1
11	2145-170-3	Hose Stand	1
12	63-107	1/2NC Lock Nut	1
13	62-300	1/2NC x 1" GD5 Cap Screw	1
14	60-102	Klick Pin	1
15	4830-0-5	Upper Link Pin	1
16	60-615	3/8" DIA. x 2" Roll Pin	2
17	72-351	Safety Chain	1
18	5630-0-23	Wrench	1
19	5510-127-0	Wing Nut	2
20	53-113	Wear Sleeve	2
21	60-606	1/4" DIA. x 2" Roll Pin	2
22	6127-0-11	1-1/4" DIA. x 6-3/4" Pin	1
23	62-176	5/8NC x 3-1/2" GD5 Cap Screw	1
24	63-110	5/8NC Lock Nut	1
25	4885-0-5	Hitch Pin	1
26	2135-54-0	Hitch	1
27	4885-0-6	Tongue Bushing	1
28	63-106	1/2NC Hex Nut	1
29	64-108	1/2" STD. Flat Washer	1
30	64-107	1/2" STD. Lock Washer	1
31	6200-90-0	Pin Assembly (Includes ★ Items Below)	1
32	★ 6200-90-1	1/2" DIA. x 6" Clevis Pin	1
33	★ 60-716	#3 Hair Pin Cotter	1
34	★ 60-626	3/16" DIA. x 1-1/2" Roll Pin	1

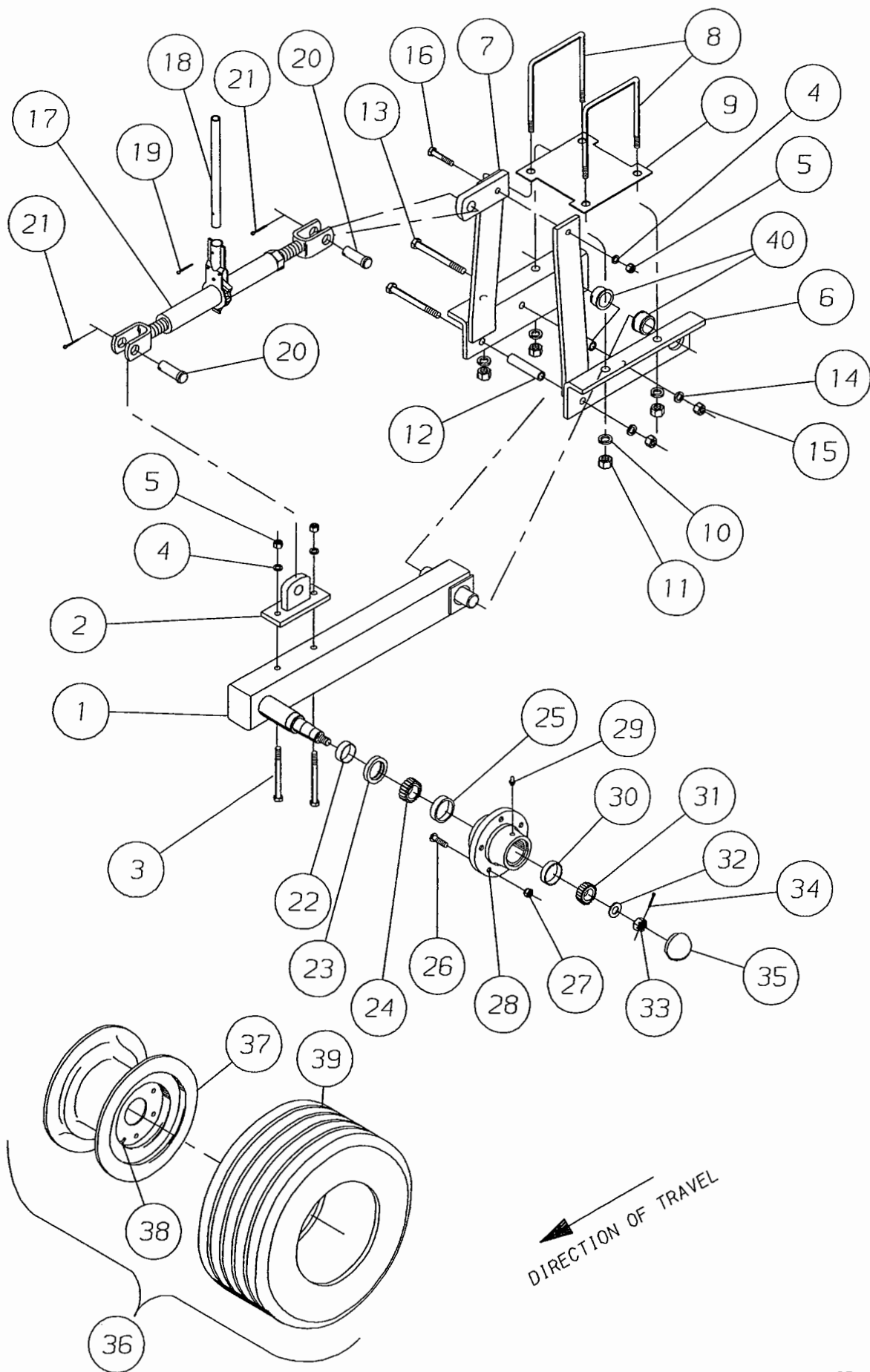

REV. 1/25/01  
M4830-9



# SPRING RESET SHANK ASSEMBLY

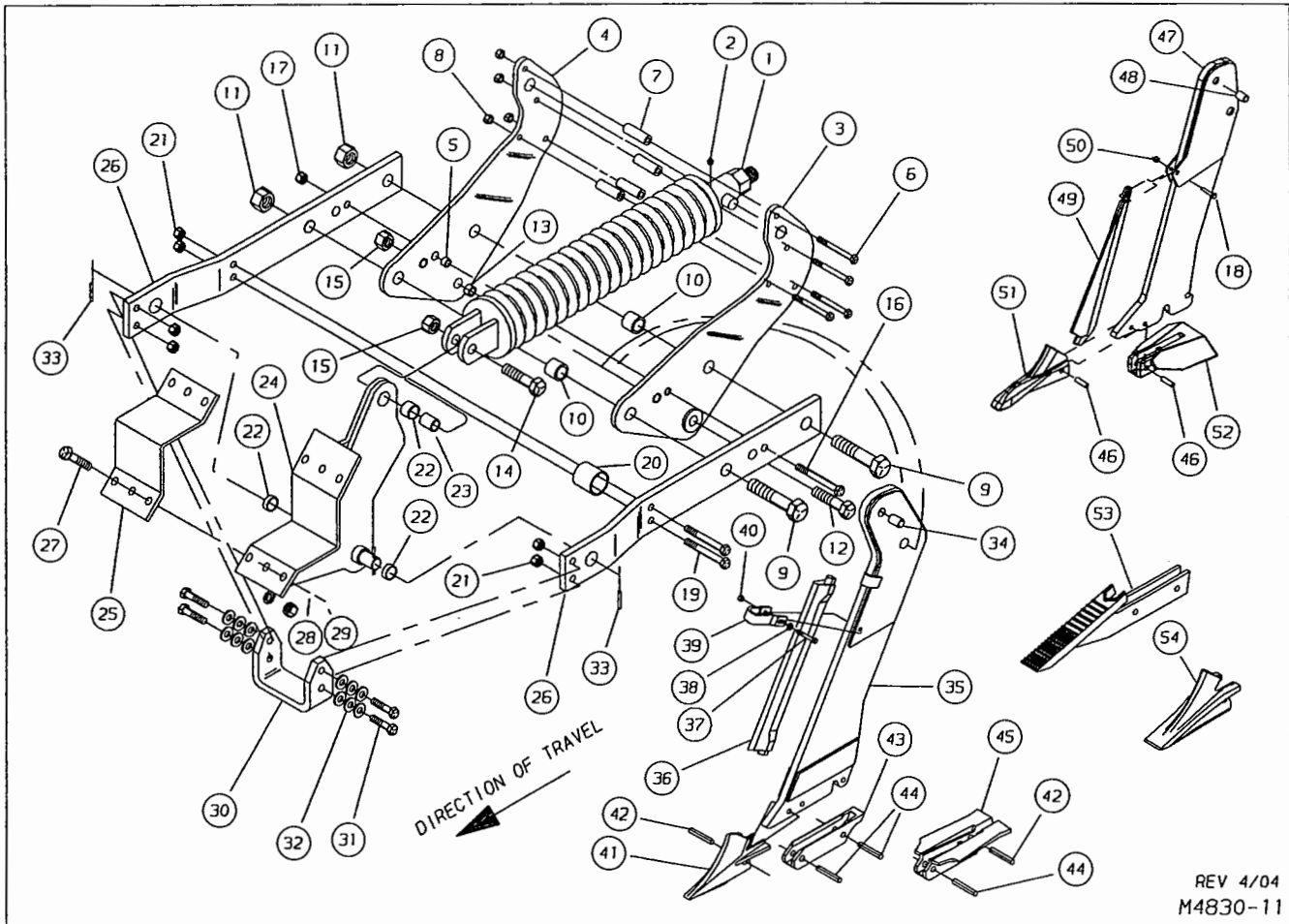

REV 4/04  
M4830-11

## FOR MODELS - ALL

6/04

Item	Part Number	Part Description	Qty.	Item	Part Number	Part Description	Qty.
1	4830-26-0A	Spring Assembly	1	28	64-112	3/4" STD. Lock Washer	6
2	65-110	1/8" Spin Drive Zerk	1	29	63-112	3/4NC Hex Nut	6
3	4885-87-0B	Left Trunnion Bracket Assembly	1	30	4885-76-1	Doubler	1
4	4885-88-0B	Right Trunnion Bracket Assembly	1	31	62-441	5/8NC x 2-1/2" GD5 Cap Screw	4
5	53-119	Wear Bushing	2	32	64-110	5/8" STD. Flat Washer	12
6	62-351	1/2NC x 4-1/2" GD5 Cap Screw	4	33	60-606	1/4" DIA. x 2" Roll Pin	2
7	4885-80-1	Spacer Tube	4	34	53-168	Wear Bushing	1
8	63-107	1/2NC Lock Nut	4	35	4830-82-0C	Subsoil Shank Weldment	1
9	62-742	1-1/4NC x 5-1/2" GD5 Machine Bolt	2	36	33-197	Ripper Wear Bar	1
10	4885-80-2	Spacer Tube	2	37	62-394	5/16NC x 2-1/2"GD5 Cap Screw	1
11	63-126	1-1/4NC Lock Nut	3	38	64-102	5/16" STD. Flat Washer	1
12	4885-80-3	1NC x 4" Special Bolt	1	39	4830-125-4	Retainer	1
13	53-103	Wear Bushing	2	40	63-139	5/16NC Lock Nut	1
14	62-820	1NC x 4" GD8 Cap Screw	1	41	33-194	3/4" Ripper Point	1
15	63-119	1NC Lock Nut	2	42	60-131	1/2" x 1-3/4"Spiral Expansion Pin	2
16	62-439	5/8NC x 5" GD5 Cap Screw	1	43	33-195	Low Disturbance Shank Cap	1
17	63-110	5/8NC Lock Nut	1	44	60-130	1/2" x 1-1/2"Spiral Expansion Pin	2
18	62-415	3/8NC x 1-3/4"GD5 Cap Screw	1	45	33-196	Shattering Wing	1
19	62-339	5/8NC x 4-1/2" GD5 Cap Screw	2	46	60-131	1/2 x 1-3/4"Spiral Expansion Pin	2
20	4850-26-1	Spacer Tube	1	47	4830-182-0	No-Till Ripper Shank Weldment	1
21	63-110	5/8NC Lock Nut	2	48	53-168	Wear Sleeve	1
22	53-101	Wear Bushing	3	49	33-213	Ripper Wear Bar	1
23	53-148	Bushing	1	50	63-134	3/8NC Nylon-Top Lock Nut	1
24	4830-84-0A	Shank Clamp Weldment	1	51	33-211	No-Till Ripper Point	1
25	31-208	Clamp	1	52	33-212	No-Till Ripper Wing	1
26	31-190	Shank Arm	2	53	4830-132-0	Point Hard Surfaced	1
27	62-195	3/4NC x 2-1/2" GD5 Cap Screw	6	54	33-205	2" Ripper Point	1

# PATHFIND'R™ SHANK ASSEMBLY

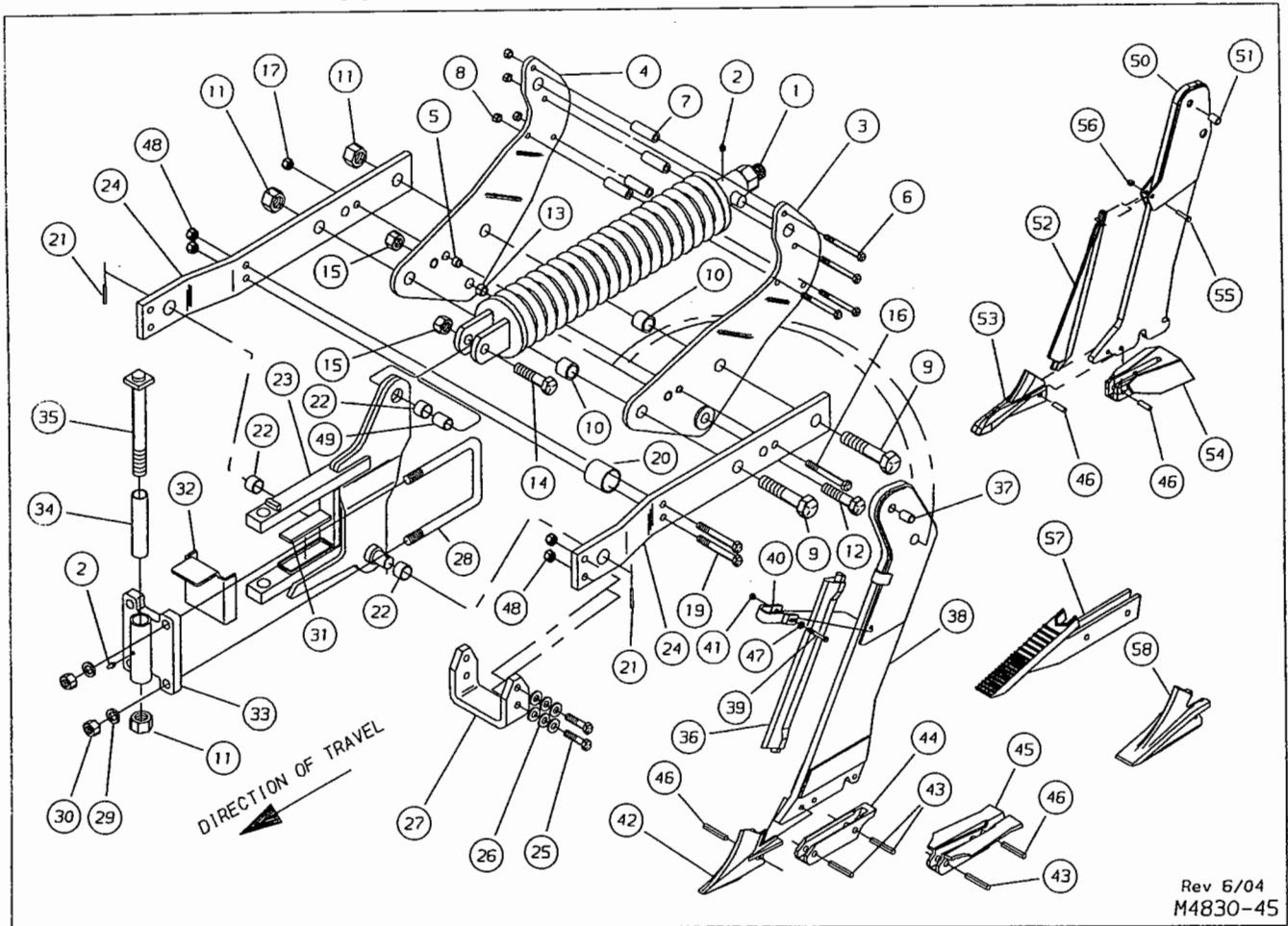

Rev 6/04  
M4830-45

Item	Part Number	Part Description	Qty.	Item	Part Number	Part Description	Qty.
1	4830-26-0A	Spring Assembly	1	30	63-115	7/8NC Hex Nut	4
2	65-110	1/8" Spin Drive Zerk	2	31	4830-125-3	Wear Pad	1
3	4885-87-0B	Left Trunnion Bracket Assembly	1	32	4830-125-1	Stop Plate	1
4	4885-88-0B	Right Trunnion Bracket Assembly	1	33	4830-185-0A	Pivot Tube Casting	1
5	53-119	Wear Bushing	2	34	4830-125-2	Pivot Wear Sleeve	1
6	62-351	1/2NC x 4-1/2" GD5 Cap Screw	4	35	4830-190-0	Pivot Pin Weldment	1
7	4885-80-1	Spacer Tube	4	36	33-197	Ripper Wear Bar	1
8	63-107	1/2NC Lock Nut	4	37	53-168	Wear Bushing	1
9	62-742	1-1/4NC x 5-1/2" GD5 Mach. Bolt	2	38	4830-82-0C	Subsoil Shank Weldment	1
10	4885-80-2	Spacer Tube	2	39	62-394	5/16NC x 2-1/2" GD5 Cap Screw	1
11	63-126	1-1/4NC Lock Nut	3	40	4830-125-4	Retainer	1
12	4885-80-3	1NC x 4" Special Bolt	1	41	63-139	5/16NC Lock Nut	1
13	53-103	Wear Bushing	2	42	33-194	Ripper Point	1
14	62-820	1NC x 4" GD8 Machine Bolt	1	43	60-130	1/2" x 1-1/2" Spiral Expansion Pin	2
15	63-119	1NC Lock Nut	2	44	33-195	Low Disturbance Shank Cap	1
16	62-439	5/8NC x 5" GD5 Cap Screw	1	45	33-196	Shattering Wing	1
17	63-110	5/8NC Lock Nut	1	46	60-131	1/2" x 1-3/4" Spiral Expansion Pin	2
18				47	64-102	5/16" STD. Flat Washer	1
19	62-339	5/8NC x 4-1/2" GD5 Cap Screw	2	48	63-110	5/8NC Lock Nut	6
20	4850-26-1	Spacer Tube	1	49	53-148	Wear Bushing	1
21	60-606	1/4" DIA. x 2" Roll Pin	2	50	4830-182-0	No-Till Ripper Shank Weldment	1
22	53-101	Wear Bushing	3	51	53-168	Wear Sleeve	1
23	4830-184-0	Pivot Shank Lug	2	52	33-213	No-Till Ripper Wear Bar	1
24	31-190	Shank Arm	2	53	33-211	No-Till Ripper Point	1
25	62-441	5/8NC x 2-1/2" GD5 Cap Screw	4	54	33-212	No-Till Ripper Wing	1
26	64-110	5/8" STD. Flat Washer	12	55	62-415	3/8NC x 1-3/4" GD5 Cap Screw	1
27	4885-76-1	Doubler	1	56	63-134	3/8NC Nylon-Top Lock Nut	1
28	61-281	7/8" DIA. U-Bolt	2	57	4830-132-0	Point, Hard Surfaced	1
29	64-115	7/8" STD. Lock Washer	4	58	33-205	2" Ripper Point	1

# SHEAR BOLT SHANK ASSEMBLY

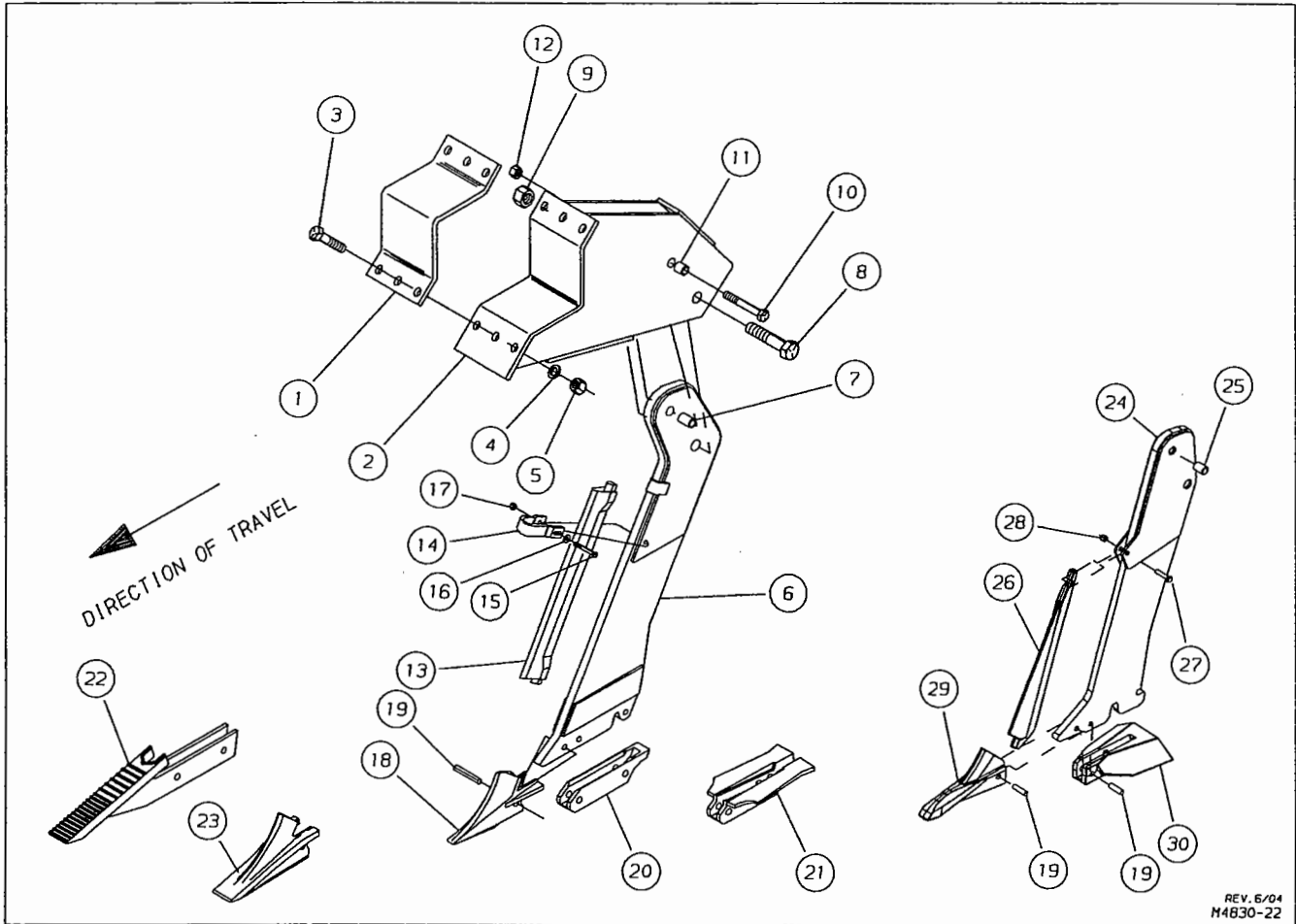

REV. 6/04  
H4630-22

## FOR MODELS - ALL

6/04

Item	Part Number	Part Description	Qty.
		Shear Bolt Shank Assembly	1
1	31-208	Clamp	1
2	4830-85-0B	Shank Clamp Weldment	1
3	62-195	3/4NC x 2-1/2" GD5 Cap Screw	6
4	64-112	3/4" STD. Lock Washer	6
5	63-112	3/4NC Hex Nut	6
6	4830-82-0C	Subsoil Shank Weldment	1
7	53-168	Wear Bushing	1
8	62-481	1NC x 4-1/2" GD5 Cap Screw	1
9	63-119	1NC Lock Nut	1
10	62-178	5/8NC x 4" GD5 Cap Screw	1
11	53-167	Wear Sleeve	2
12	63-110	5/8NC Lock Nut	1
13	33-197	Ripper Wear Bar	1
14	4830-125-4	Retainer	1
15	62-394	5/16NC x 2-1/2" GD5 Cap Screw	1
16	64-102	5/16" STD. Flat Washer	1

Item	Part Number	Part Description	Qty.
17	63-139	5/16NC Lock Nut	1
18	33-194	3/4" Ripper Point	1
19	60-131	1/2" x 1-3/4" Spiral Expansion Pin	2
20	33-195	Low Disturbance Shank Cap	1
21	33-196	Shattering Wing	1
22	4830-132-0	Point, Hard Surfaced	1
23	33-205	2" Ripper Point	1
		No-Till Ripper Shank	
24	4830-182-0	No-Till Ripper Shank Weldment	1
25	53-168	Wear Sleeve	1
26	33-213	No-Till Ripper Shank Wear Bar	1
27	62-415	3/8NC x 1-3/4" GD5 Cap Screw	1
28	63-134	3/8NC Nylon-Top Lock Nut	1
29	33-211	No-Till Ripper Point	1
30	33-212	No-Till Ripper Wing	1

# SHANK STAGGER WELDMENT

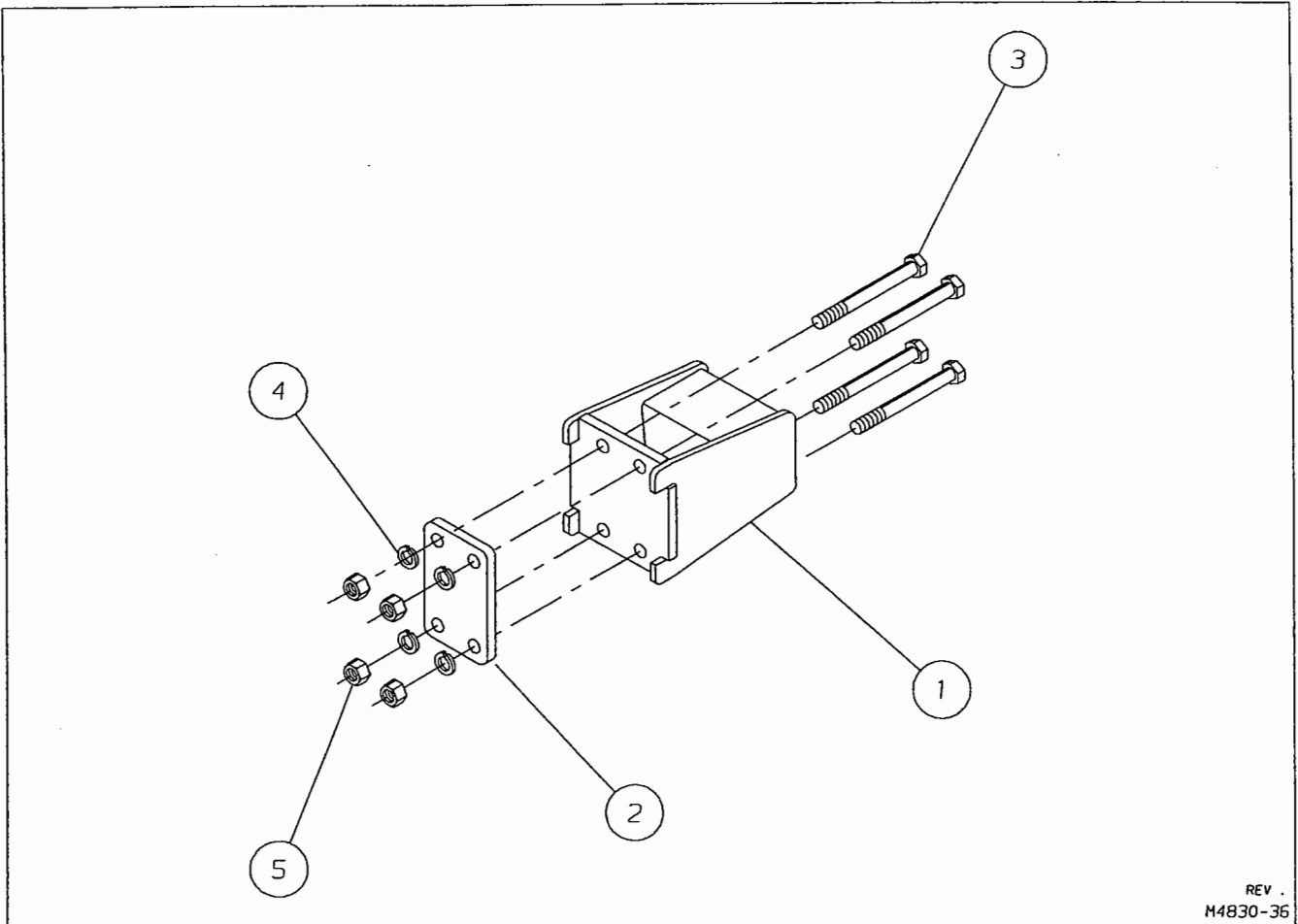

REV .  
M4830-36

**FOR MODELS - ALL**

4/03

<i>Item</i>	<i>Part Number</i>	<i>Part Description</i>	<i>Qty.</i>
1	4830-227-0	Shank Stagger Weldment	1
2	4830-0-20	Plate	1
3	62-651	1NC x 9" Machine Bolt	4
4	64-118	1" STD. Lock Washer	4
5	63-117	1NC Hex Nut	4

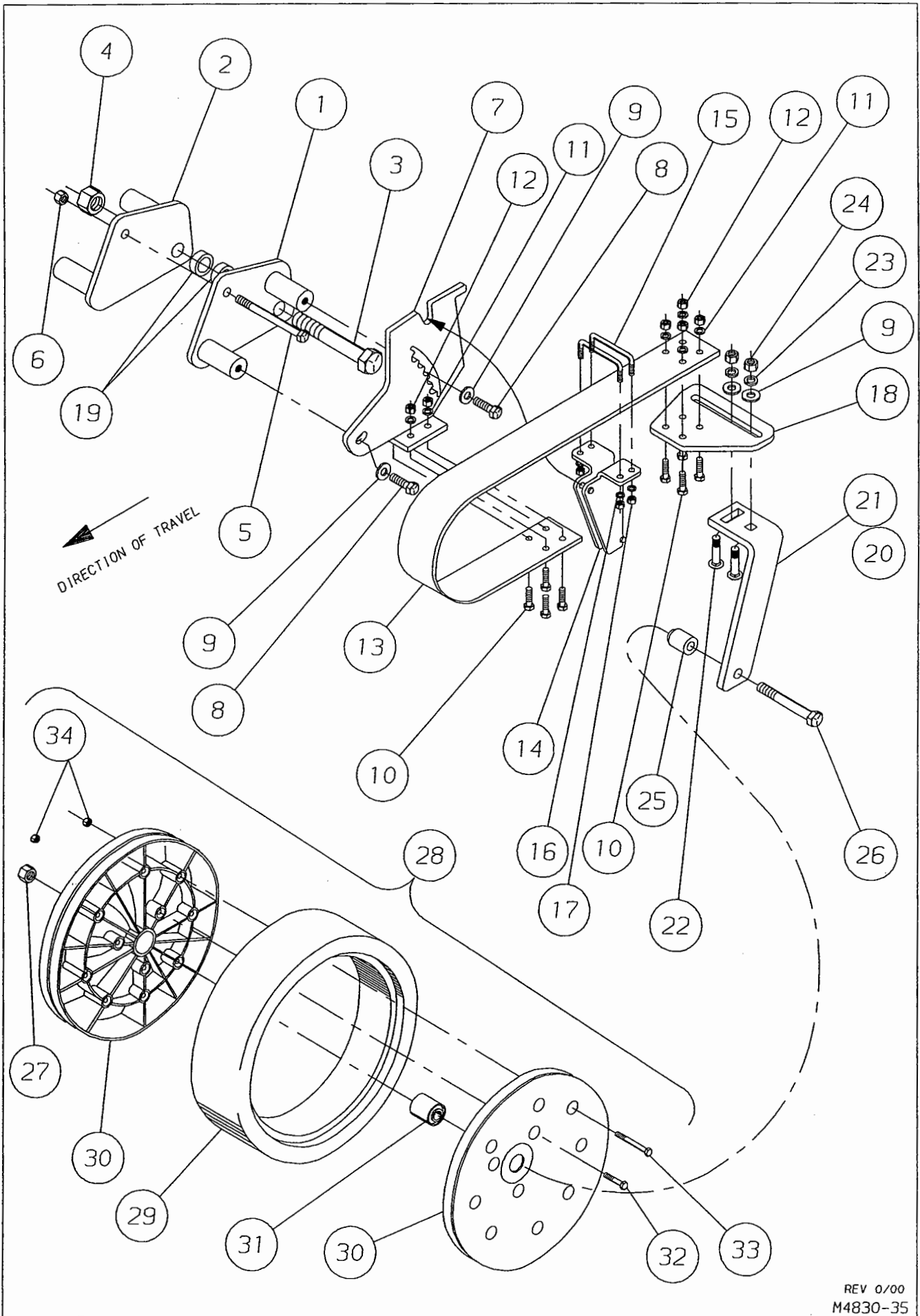

REV 0/00  
M4830-35



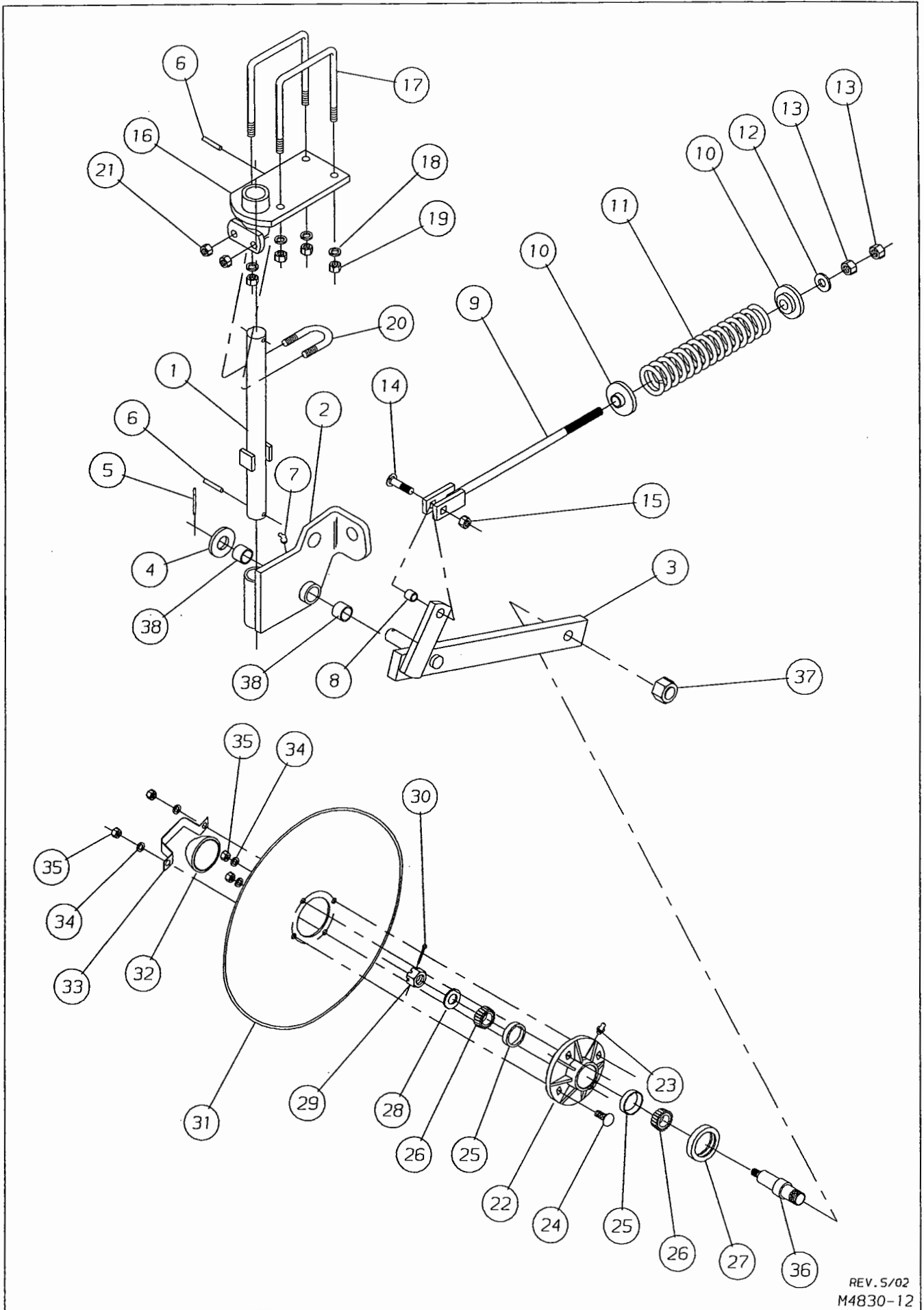

REV. 5/02  
M4830-12





# HYDRAULICS - RIGID FRAME & PULL HITCH

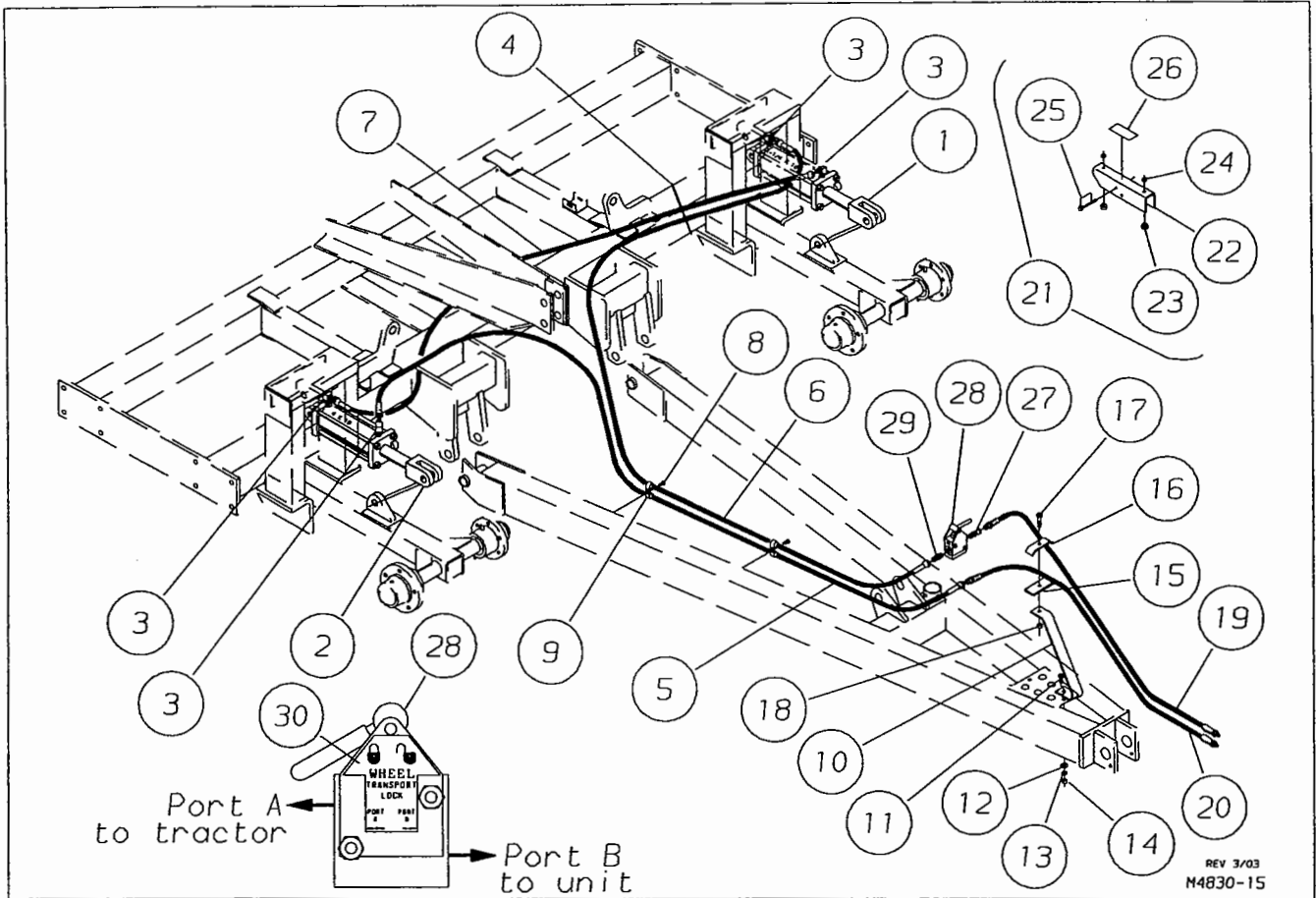

REV 3/03  
M4830-15

## FOR MODELS - ALL

9/01

Item	Part Number	Part Description	Qty.
1	21-1008	4-1/4 x 10 Hydraulic Cylinder	1
2	21-1007	4 x 10 Hydraulic Cylinder	1
3	25-301	O-Ring to 37° Flare 90° Hydraulic Fitting	4
4	25-126	Panduit Stay Strap	8
5	24-229R	3/8 x 157" Black 2W JIC Hydraulic Hose	1
6	24-233R	3/8 x 184" Black 2W JIC Hydraulic Hose	1
7	24-225R	3/8 x 140" Black 2W JIC Hydraulic Hose	1
8	62-491	3/8NF x 3/4" GD5 Cap Screw	2
9	25-1153	5/8" Hose Clamp	4
10	2145-170-3	Hose Stand	1
11	62-300	1/2NC x 1" GD5 Cap Screw	1
12	64-108	1/2" STD. Flat Washer	1
13	64-107	1/2" STD. Lock Washer	1
14	63-106	1/2NC Hex Nut	1
15	2145-170-5	Hose Plate	1
16	2426-170-5	Hose Clamp	1
17	62-343	1/2NC x 2" GD5 Cap Screw	1
18	63-107	1/2NC Lock Nut	1
19	★ 4830-93-0	3/8" x 78" (Red/Black Plastic Handle) Hose Assembly	1
20	★ 4830-94-0	3/8" x 78" (Black/Black Plastic Handle) Hose Assembly	1
21	4830-37-0	Lock Assembly	2
22	6124-17-1	Lock	1
23	44-107	Threaded Bumper	2
24	63-102	3/8NC Hex Nut	2
25	60-103	5/16" DIA. P.T.O. Pin	1
26	205-8737	Maintenance Lock Decal	1
27	25-314	O-Ring 37°(F) Flare Hydraulic Fitting	1
28	25-2272	Check Valve, Manual Release	1
29	25-300	O-Ring 37°(M) Flare Hydraulic Fitting	1
30	74-574	Decal, Wheel Transport Lock	1

★ See page P24 for detailed parts listing

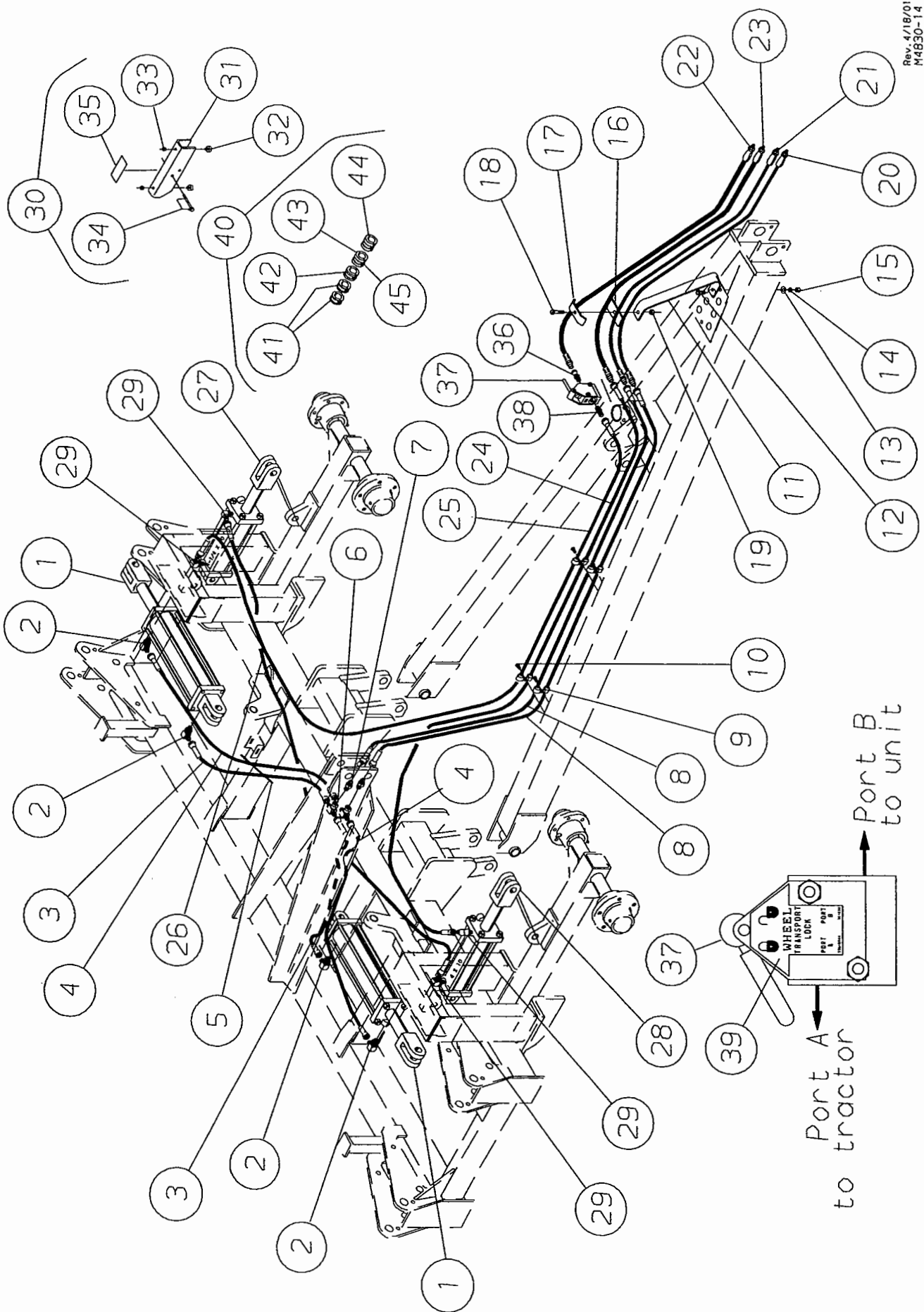



# HYDRAULIC HOSE WITH PLASTIC GRIP ASSEMBLIES

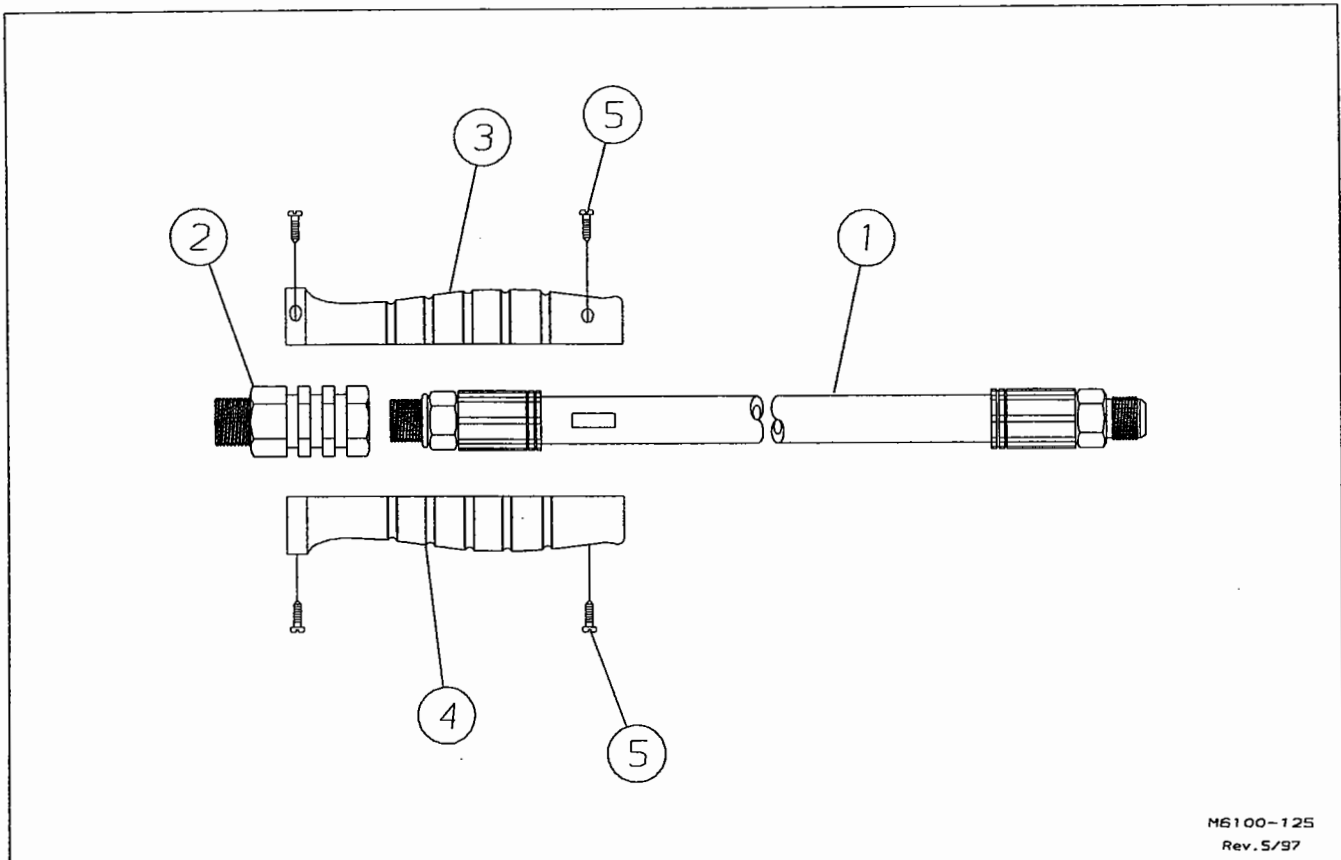

M6100-125  
Rev. 5/97

## FOR MODELS - ALL

9/01

Item	Part Number	Part Description	Qty.
	4830-93-0	3/8" x 78" 100R2 Hose with Red/Black Grip Assembly	1
1	24-2120R	3/8" DIA. x 78" JIC/ORB 100R2 Hose	1
2	25-2295	3/4 ORB to 1/2 NPT Hydraulic Fitting	1
3	25-2289	Hose Grip Half - Red	1
4	25-2291	Hose Grip Half - Black	1
5	62-656	Screw	4
	4830-94-0	3/8" x 78" 100R2 Hose with Black/Black Grip Assembly	1
1	24-2120R	3/8" DIA. x 78" JIC/ORB 100R2 Hose	1
2	25-2295	3/4 ORB to 1/2 NPT Hydraulic Fitting	1
3	25-2291	Hose Grip Half - Black	1
4	25-2291	Hose Grip Half - Black	1
5	62-656	Screw	4
	4830-91-0	3/8" x 57" 100R2 Hose with Red/Yellow Grip Assembly	1
1	24-2104R	3/8" x 57" JIC/ORB 100R2 Hose	1
2	25-2295	3/4 ORB to 1/2 NPT Hydraulic Fitting	1
3	25-2289	Hose Grip Half - Red	1
4	25-2290	Hose Grip Half - Yellow	1
5	62-656	Screw	4
	4930-92-0	3/8" x 57" 100R2 Hose with Yellow/Yellow Grip Assembly	1
1	24-2104R	3/8" x 57" JIC/ORB 100R2 Hose	1
2	25-2295	3/4 ORB to 1/2 NPT Hydraulic Fitting	1
3	25-2290	Hose Grip Half - Yellow	1
4	25-2290	Hose Grip Half - Yellow	1
5	62-656	Screw	4

# PRINCE HYDRAULIC CYLINDER

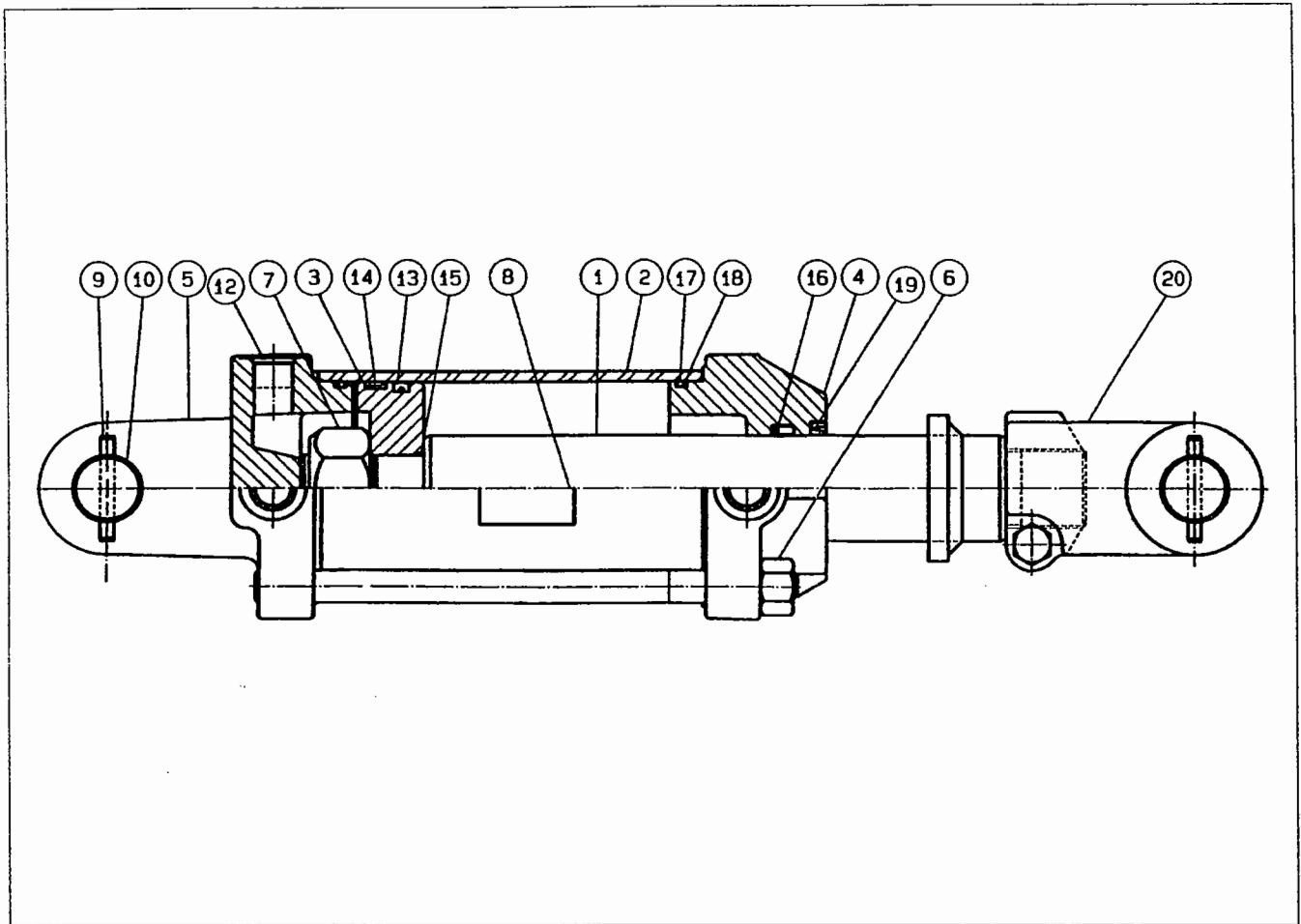

**21-171 4" X 16" PRINCE HYDRAULIC CYLINDER ASSEMBLY (STD) 11/99**  
**Retracted - 31-1/2" Stroke - 16" Extended - 47-1/2" Rod Diameter - 2"**

Item	Part Number	Part Description	Qty.
1	21-893	Piston Rod	1
2	21-282	Tube	1
3	21-879	Piston	1
4	21-894	Gland	1
5	21-738	Butt	1
6	21-288	Tie Rod Assembly	4
7	21-286	Lock Nut	1
8	74-113	Cylinder Warning Decal	1
9		1/4" DIA. x 2" Roll Pin	4
10	21-859	Clevis Pin	2
11			
12	21-404	#8 SAE Plug	3
13	★	Crown Seal	1
14	★	Bearing Ring	1
15	★	O-Ring	1
16	★	U-Cup	1
17	★	O-Ring	1
18	★	Back-Up Washer	2
19	★	Wiper	1
20	21-685	Clevis Assembly	1
	● 21-895	Seal Kit (★ Items Included in Kit)	
	●	Not Included in Cylinder Assembly	

# PRINCE HYDRAULIC CYLINDER

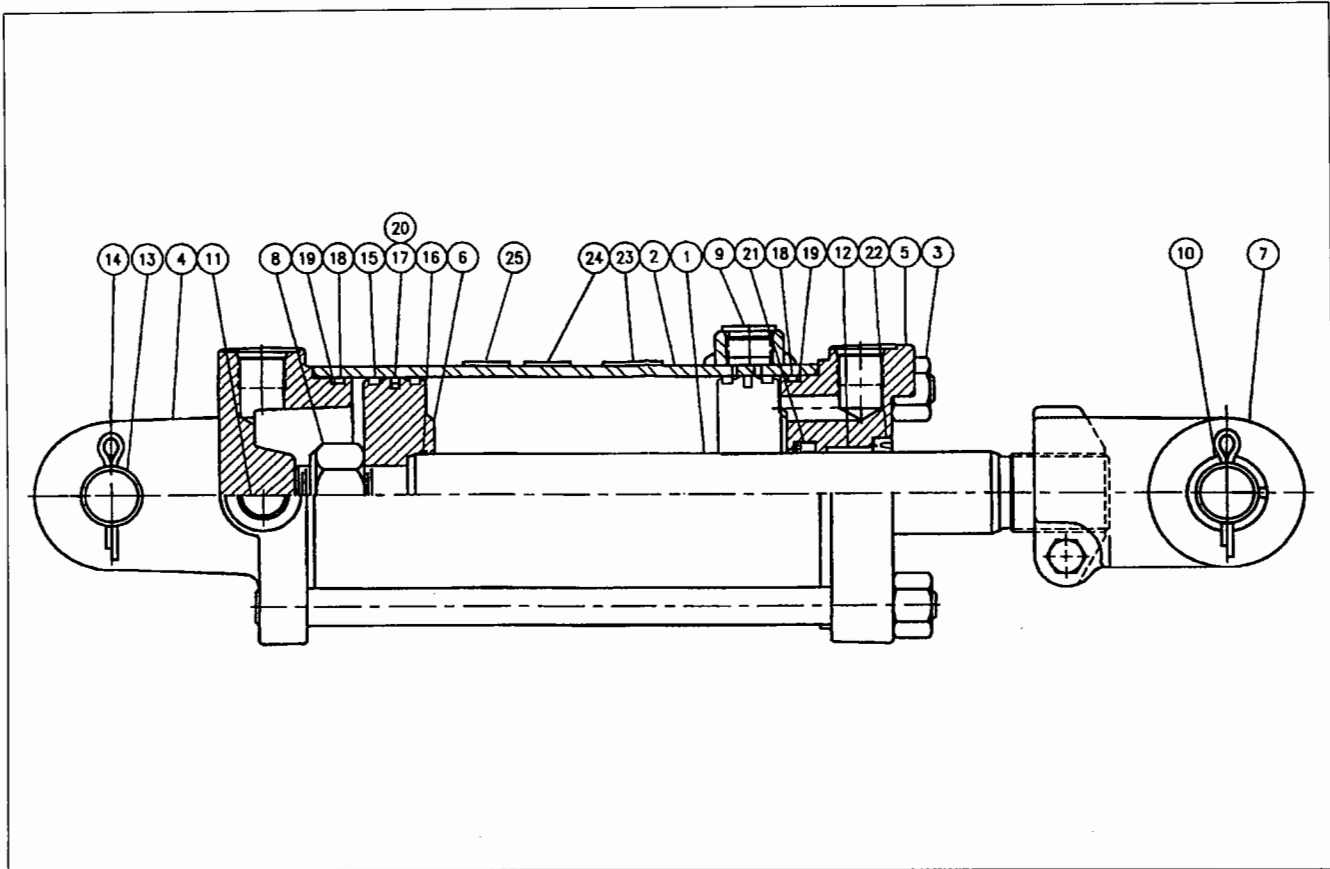

**21-1007 4" X 10" PRINCE HYDRAULIC CYLINDER ASSEMBLY (Series) 4/04**  
**Retracted - 22-1/4" Extended - 32-1/4" Stroke - 10" Rod Diameter - 1-3/8"**

Item	Part Number	Part Description	Qty.
1	21-2061	Piston Rod	1
2	21-2063	Tube	1
3	21-381	Tie Rod Assembly	4
4	21-337	Butt	1
5	21-810	Gland	1
6	21-811	Piston	1
7	21-2126	Clevis Assembly	1
8	21-225	Lock Nut	1
9	21-702	ORB Plug	1
10	21-2127	Bushing	2
11	21-404	#8 SAE Plug	3
12	21-807	Bushing	1
13	21-260	Clevis Pin	2
14		3/16" DIA. x 1-3/4" Cotter Pin	4
15	★	Bearing Ring	1
16	★	O-Ring	1
17	★	O-Ring	1
18	★	O-Ring	2
19	★	Back-Up Washer	2
20	★	Teflon Seal	1
21	★	U-Cup	1
22	★	Wiper	1
23	74-516	Seal Kit Decal	1
24	21-443	Series Caution Decal	1
25	74-113	Cylinder Warning Decal	1
	21-2059	Seal Kit (★ Items Included in Kit)	

# PRINCE HYDRAULIC CYLINDER

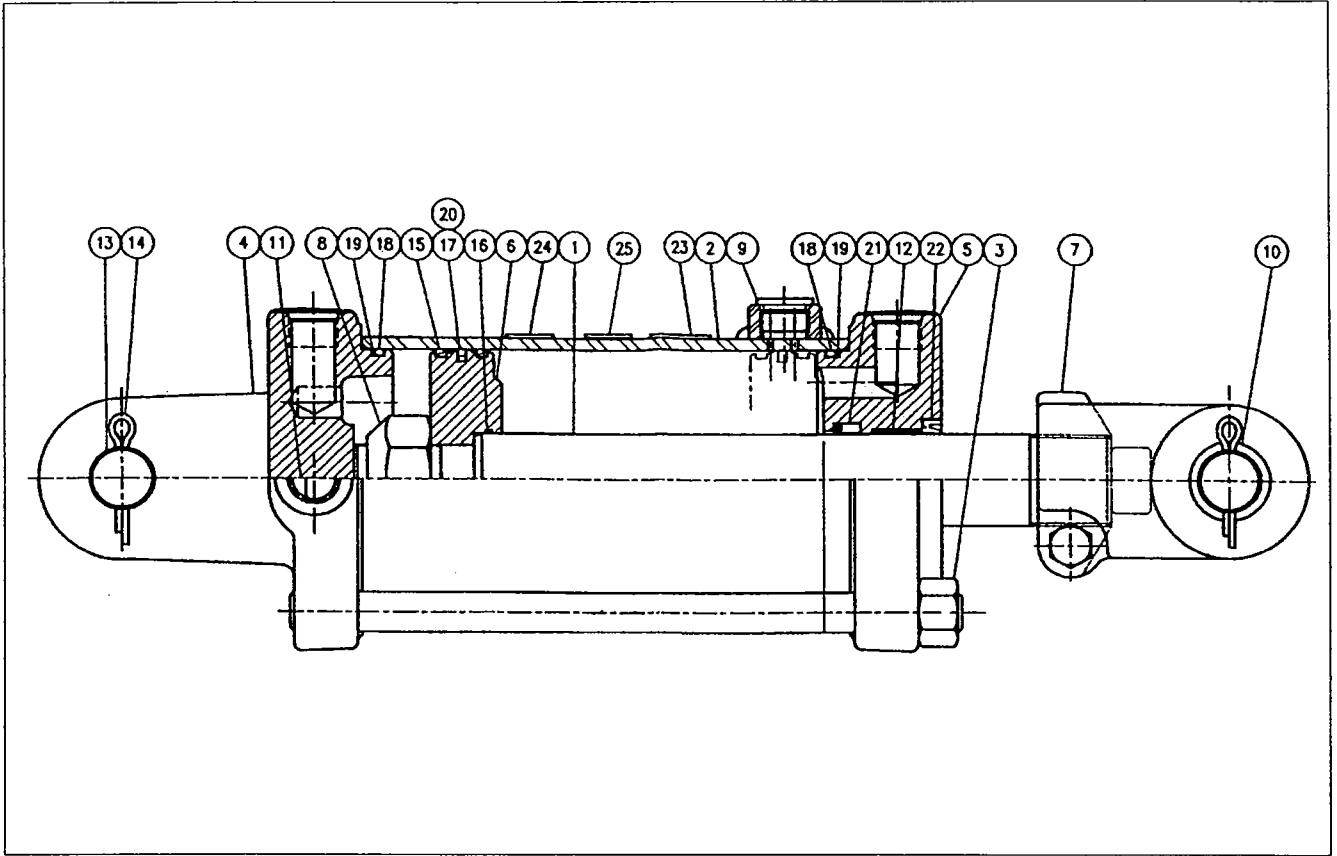

**21-1008 4-1/4" X 10" PRINCE HYDRAULIC CYLINDER ASSEMBLY (Series) 9/01**  
**Retracted - 22-1/4" Extended - 32-1/4" Stroke - 10" Rod Diameter - 1-1/2"**

Item	Part Number	Part Description	Qty.
1	21-2062	Piston Rod	1
2	21-2065	Tube	1
3	21-381	Tie Rod Assembly	4
4	21-2072	Butt	1
5	21-2073	Gland	1
6	21-2074	Piston	1
7	21-2125	Clevis Assembly	1
8	21-819	Lock Nut	1
9	21-702	Port Plug	1
10	21-2127	Bushing	2
11	21-404	#8 SAE Plug	3
12	21-2069	Bushing	1
13	21-260	Clevis Pin	2
14		3/16" DIA. x 1-3/4" Cotter Pin	4
15	*	Bearing Ring	1
16	*	O-Ring	1
17	*	O-Ring	1
18	*	O-Ring	2
19	*	Back-Up Washer	2
20		Teflon Seal	1
21	*	U-Cup	1
22	*	Wiper	1
23	74-517	Seal Kit Decal	1
24	21-443	Series Caution Decal	1
25	74-113	Cylinder Warning Decal	1
	21-2060	Seal Kit (* Items Included in Kit)	

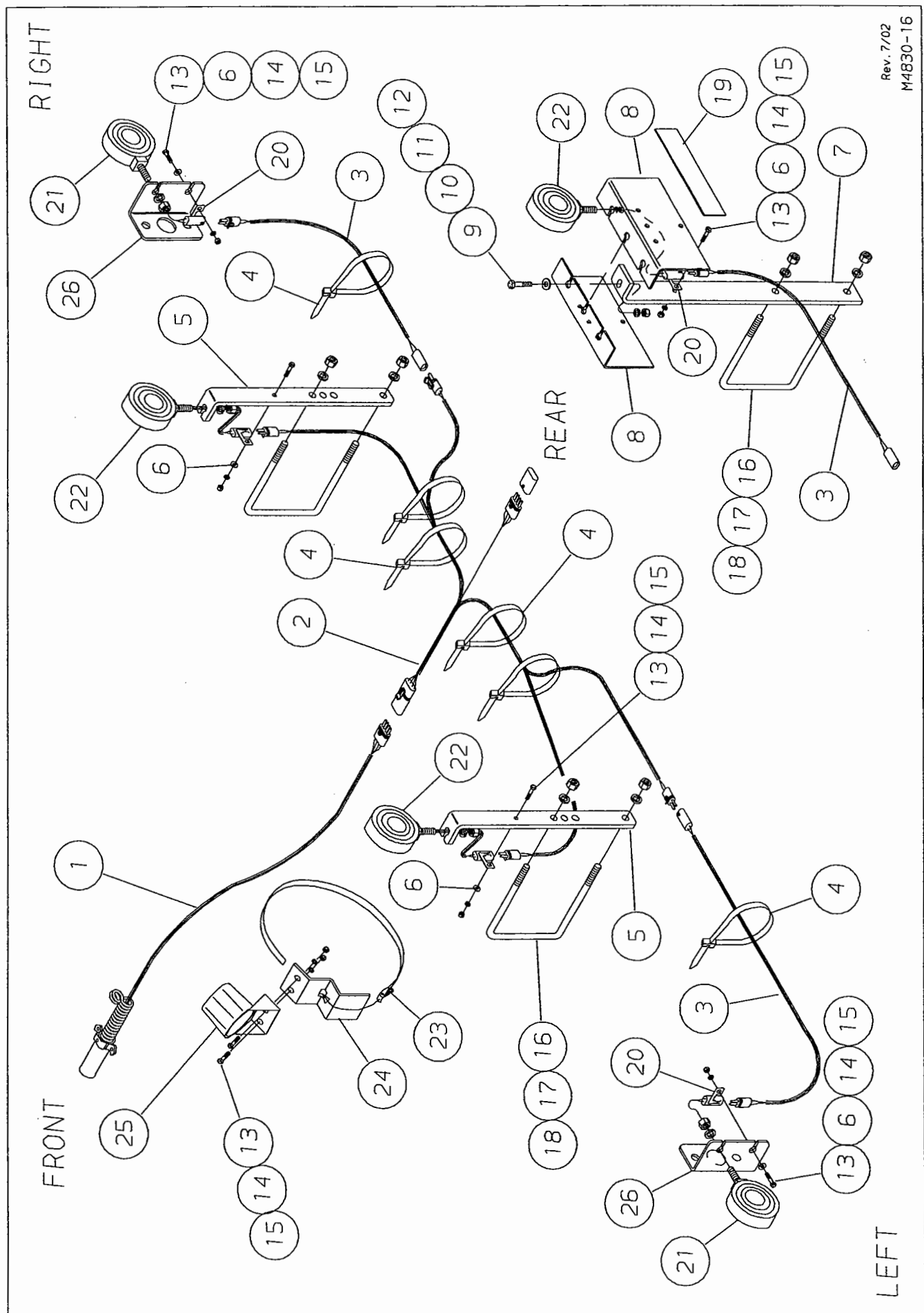

RIGHT

FRONT

REAR

LEFT

Rev. 7/02  
M4830-16

# LIGHT KIT PARTS

FOR MODELS - ALL

7/02

Item	Part Number	Part Description	Qty.
1	79-547	Wire Harness, Tractor (6')	
	79-550	Wire Harness, Tractor (22')	
2	79-546	Wire Harness, Center	
3	79-549	Wire Harness, Extension (2')	
	79-551	Wire Harness, Extension (4')	
4	25-126	Panduit Stay Strap	
5	4830-0-15	Light Bracket	
6	64-101	1/4" STD. Flat Washer	
7	4830-0-12	Light Stand	
8	4400-170-5	Light Mount Plate	
9	62-436	3/8NC x 1-1/4" GD5 Cap Screw	
10	64-104	3/8" STD. Flat Washer	
11	64-103	3/8" STD. Lock Washer	
12	63-102	3/8NC Hex Nut	
13	62-417	1/4NC x 1" GD5 Cap Screw	
14	64-100	1/4" STD. Lock Washer	
15	63-100	1/4NC Hex Nut	
16	61-268	1/2" DIA. U-Bolt	
17	64-107	1/2" STD. Lock Washer	
18	63-106	1/2NC Hex Nut	
19	74-575	Red Reflector Tape 2 x 9	
	74-576	Orange Fluorescent Tape 2 x 9	
	74-577	Yellow Reflector Tape 2 x 9	
20	79-552	Wire Harness, Retaining Clip	
21	79-394	Dual Face Amber Light	
22	79-395	Single Face Red Light	
23	25-1105	Snap Lock Clamp	
24	4200-85-5	Plug Storage Bracket	
25	79-397	Plug Storage Receptacle	
26	4830-170-1	Light Bracket (Folding Frames)	

# DECALS

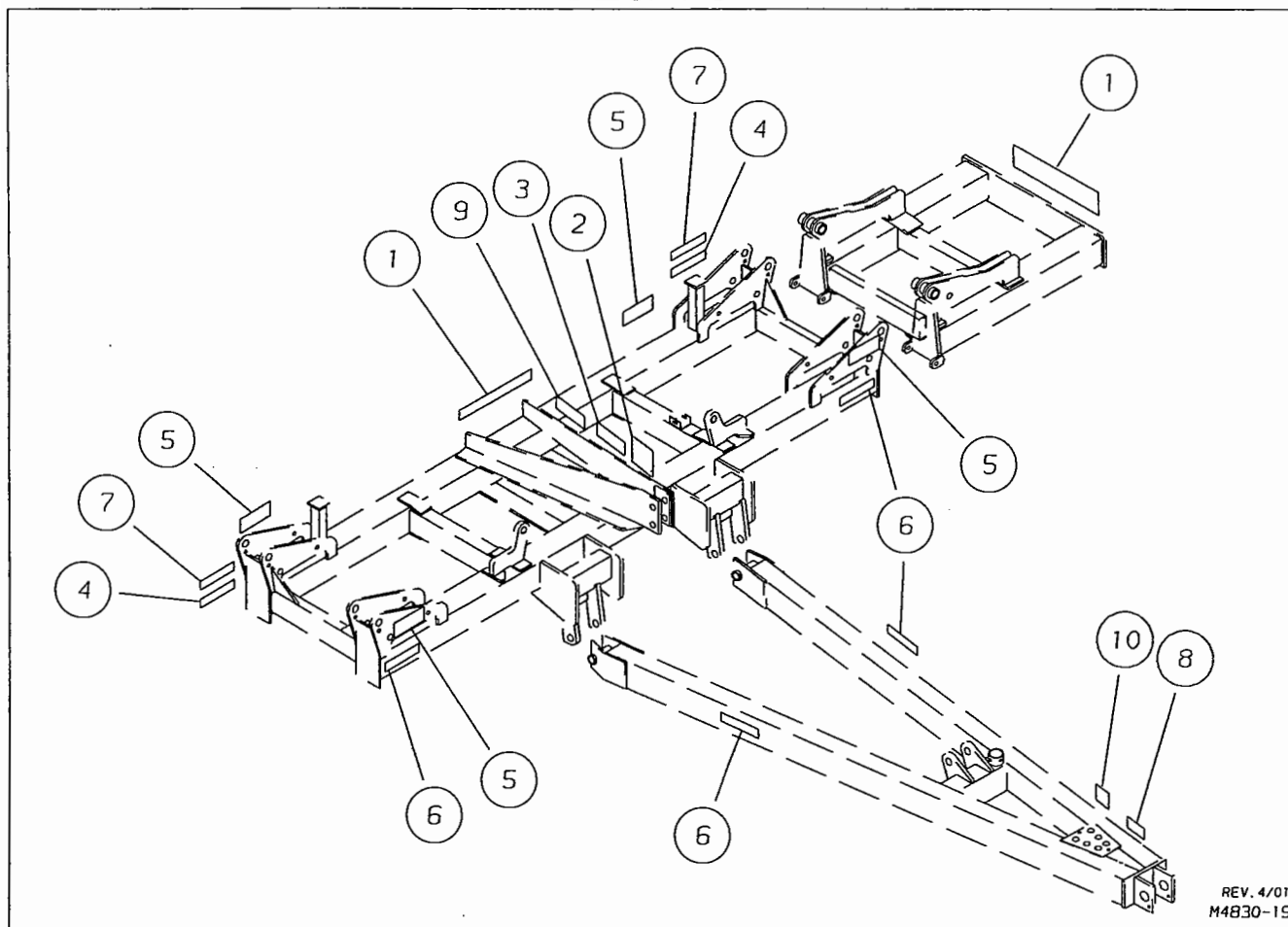

REV. 4/01  
M4830-19

## FOR MODELS -

4/04

Item	Part Number	Part Description	Qty.
1	74-100	Decal, KRAUSE	3
2	74-570	Decal, Warning Universal Text	1
3	★ 74-276	Decal, Warning Escaping Fluid	1
	● 74-102	Decal, Warning Stand Clear	1
4	74-576	Fluorescent Orange Tape 2 x 9	■ 2 / 4
5	★ 74-102	Decal, Warning Stand Clear	4
6	74-577	Yellow Reflector Tape 2 x 9	2 / 4▲
7	74-575	Red Reflector Tape 2 x 9	■ 2 / 4
8	74-550	Decal, Warning Tongue	1
9	74-549	Decal, 4830 Series	1
10	74-465	Decal, Warning Transport Lock	1

● For Rigid Models

★ For Folding Models

■ Qty. for 5 Shank ONLY and 132" Center Folding Models

▲ With Pull Hitch

# ASSEMBLY SECTION

THE FOLLOWING SECTION ILLUSTRATES A GENERAL METHOD FOR THE ASSEMBLY OF THIS SERIES KRAUSE TILLAGE TOOL. YOU MUST KNOW THE MODEL NUMBER OF THE UNIT BEING ASSEMBLED WHENEVER MAKING REFERENCE TO THIS SECTION. THE FOLLOWING PICTURES AND DRAWINGS WILL SHOW BOLTS, PINS, NUTS AND ETC., WITH THE DESCRIPTIVE SIZE AND LENGTHS IN THE ACCOMPANYING PARAGRAPH AND A PARTS LISTING REFERENCE PAGE NUMBER. IF ANY DIFFICULTY SHOULD BE ENCOUNTERED DURING THE ASSEMBLY, RECHECK THE ILLUSTRATIONS, ASSEMBLY STEPS AND PARTS LIST DRAWINGS.

# PROPER BOLT USE

DO NOT use these values if a different torque value or tightening procedure is given for a specific application. Torque values listed are for general use only. Check tightness of fasteners periodically.

Shear bolts are designed to fail under predetermined loads. Always replace shear bolts with identical grade.

Fasteners should be replaced with the same or higher grade. If higher grade fasteners are used, these should only be tightened to the strength of the original.

Tighten plastic insert or crimped steel-type lock nuts to approximately 110 percent of the dry torque shown in the chart, applied to the nut, not to the bolt head. Tighten toothed or serrated-type lock nuts to the full torque value.

**NOTE:** "Lubricated" means coated with a lubricant such as engine oil, or fasteners with phosphate and oil coatings. "Dry" means plain or zinc plated without any lubrication. **Tighten lubricated bolts to approximately 80% of dry bolts.**

BOLT SIZE	WRENCH SIZE	BLACK OR PLATED BOLTS		
		GRADE 2	GRADE 5	GRADE 8
3/8"	9/16"	20	33	45
7/16"	5/8"	32	52	70
1/2"	3/4"	50	80	105
5/8"	15/16"	100	150	210
3/4"	1-1/8"	160	260	375
7/8"	1-5/16"	175	415	600
1"	1-1/2"	250	625	880
1-1/8"	1-11/16"	375	850	1400
1-1/4"	1-7/8"	530	1100	1765
1-1/2"	2-1/4"	930	1400	2540

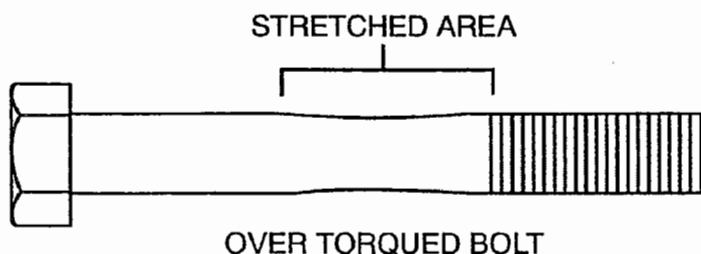

SAE  
GRADE 2



SAE  
GRADE 5



SAE  
GRADE 8

# 4830 ASSEMBLY INSTRUCTIONS

1. Before setting frame assembly on stands, raise unit high enough with lift to insert tool bar stands into brackets on front of frame. (NOTE: Tool bar stands are not provided if the unit is ordered with the optional pull hitch). Secure with pins provided.
2. Support frame and shank assembly with suitable stands at least 40" high to allow the shanks, points, coulters, gauge wheels, and other attachments to be assembled.

**Warning:** On spring shank units, support at least two of the shank assemblies at the rear of the shank assembly at all times.

**The unit will tip backwards during assembly if the shanks are not supported.**

**This could cause serious injury or death.**

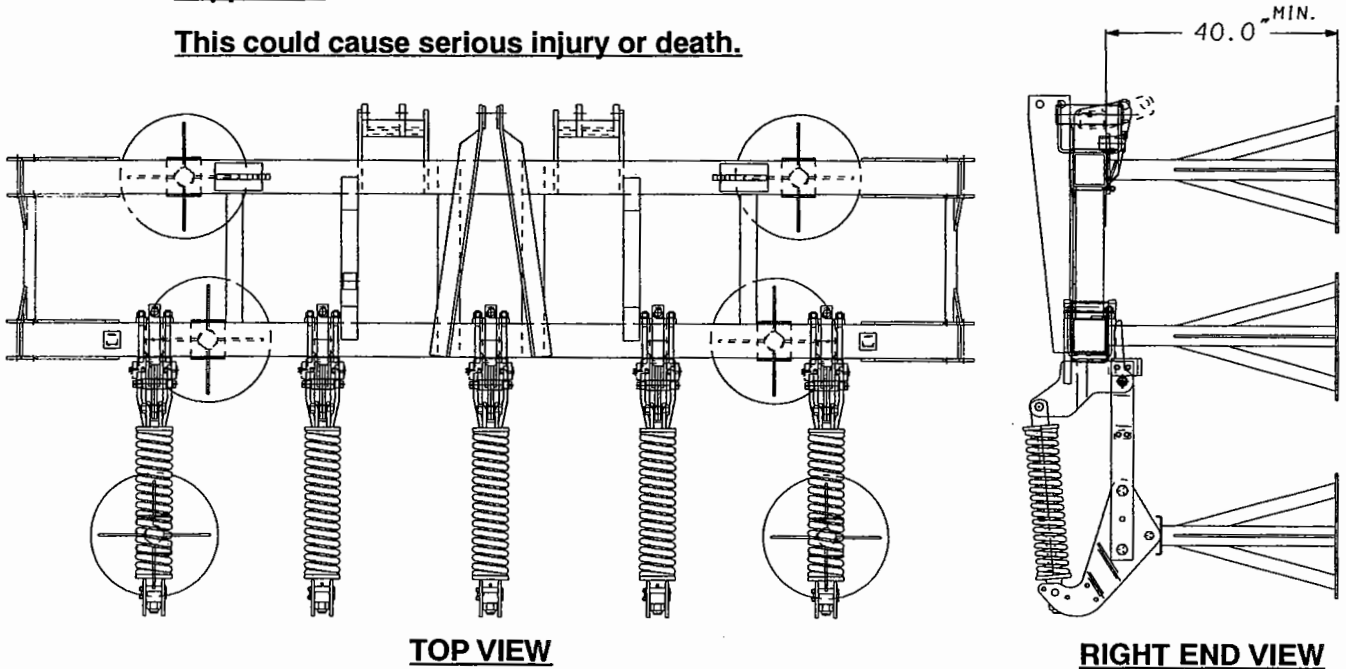

3. Slide the couler sub-assembly through the couler bracket on the frame until the top of the couler shaft is even with the top of the frame. Rotate the shaft to position the swing stop tabs so the couler may swing evenly in both directions.

NOTE: The coulters on either side of the gauge wheel assemblies will need adjusted so the couler does not swing into the gauge wheel.

Tighten the u-bolt to keep assembly in place. Install a 3/8" DIA. x 2-1/2" Roll Pin in the upper hole in the shaft.

4. Assemble the couler and hub cap retainer to the hub with 1/2NC x 1-1/2" Carriage Bolts, Lock Washers and Hex Nuts.

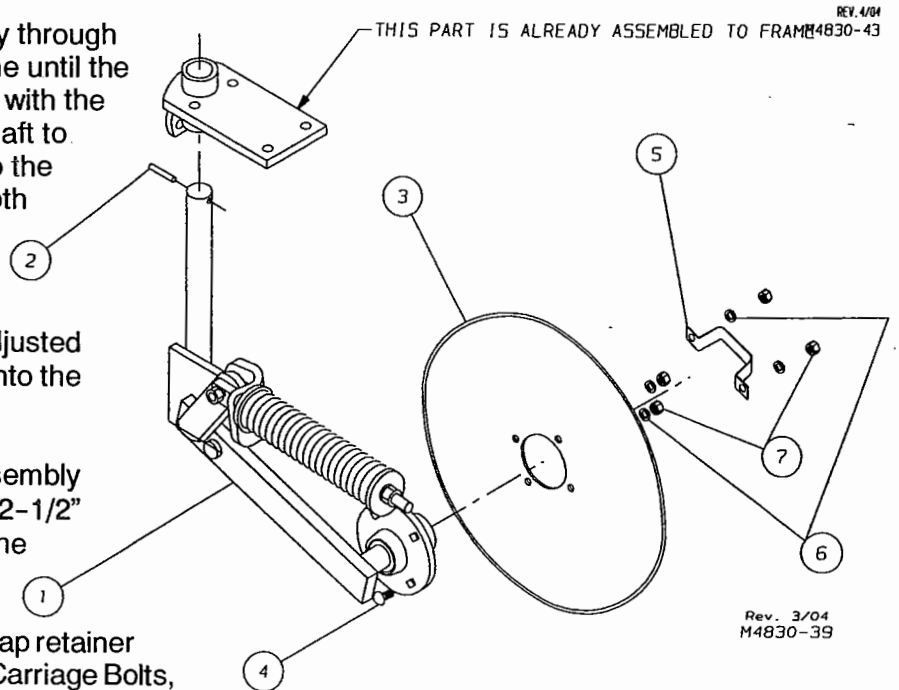

Rev. 3/04  
M4830-39

5. Assemble the gauge wheel tire to the gauge wheel sub-assembly. Raise the gauge wheels up under the rear beam between the shanks indicated in the chart and center the wheel and arm assembly between the coulters. Place the STIFFENER PLATE (4830-0-11) between the assembly and frame and fasten with 3/4" DIA. x 6-1/16"W x 7-1/2" L.U-Bolts, Lock Washers and Hex Nuts.

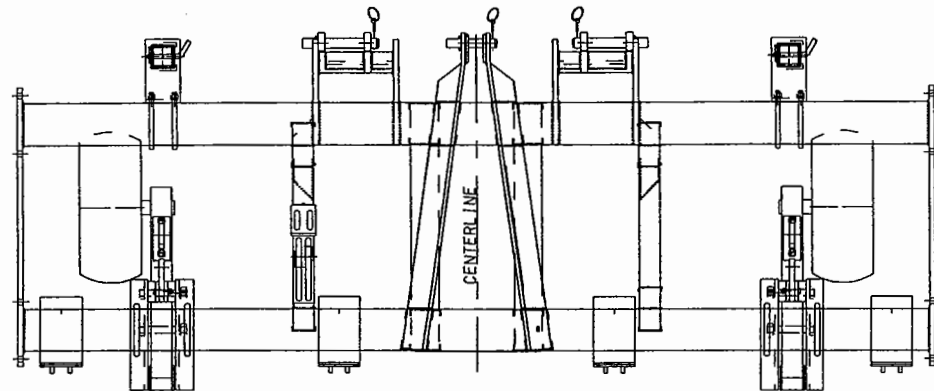
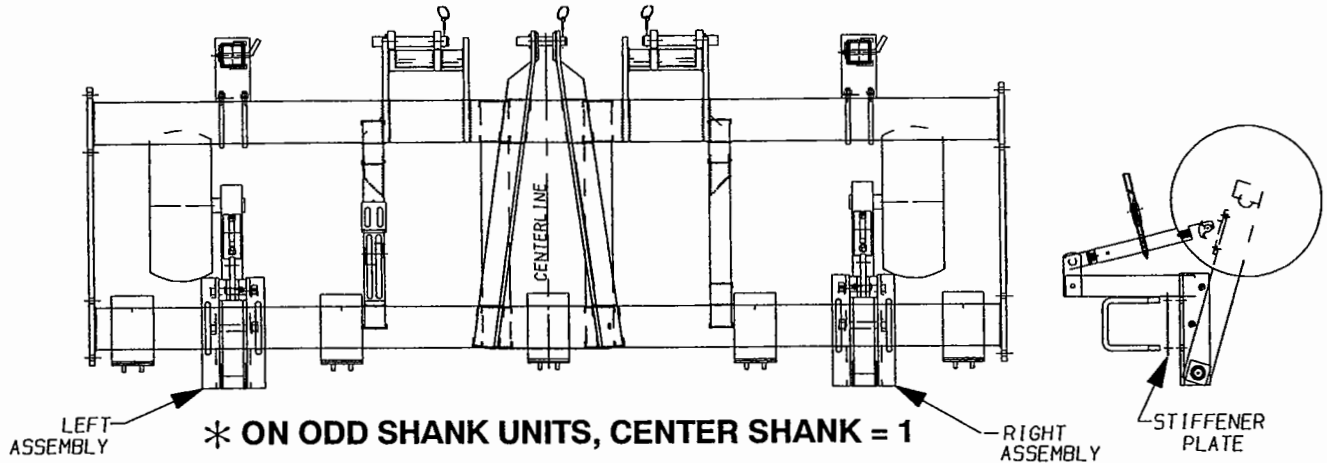

● EVEN SHANK UNITS, COUNT FROM CENTERLINE, EACH WAY

REV. 4/04  
M4830-42

MODEL	SHANK SPACING	RIGHT SIDE OF UNIT	LEFT SIDE OF UNIT	POSITION BETWEEN SHANKS #	
4830-440R	40"	LEFT ASSEMBLY	RIGHT ASSEMBLY	1 - 2	●
4830-530R	30"	RIGHT ASSEMBLY	LEFT ASSEMBLY	2 - 3	★
4830-536R	36"	RIGHT ASSEMBLY	LEFT ASSEMBLY	2 - 3	★
4830-538R	38"	RIGHT ASSEMBLY	LEFT ASSEMBLY	2 - 3	★
4830-540R	40"	RIGHT ASSEMBLY	LEFT ASSEMBLY	2 - 3	★
4830-630R	30"	LEFT ASSEMBLY	RIGHT ASSEMBLY	1 - 2	●
4830-636R	36"	LEFT ASSEMBLY	RIGHT ASSEMBLY	1 - 2	●
4830-730R	30"	RIGHT ASSEMBLY	LEFT ASSEMBLY	2 - 3	★
4830-636F	36"	LEFT ASSEMBLY	RIGHT ASSEMBLY	1 - 2	●
4830-638F	38"	LEFT ASSEMBLY	RIGHT ASSEMBLY	1 - 2	●
4830-640F	40"	LEFT ASSEMBLY	RIGHT ASSEMBLY	1 - 2	●
4830-730F	30"	RIGHT ASSEMBLY	LEFT ASSEMBLY	2 - 3	★
4830-736F	36"	RIGHT ASSEMBLY	LEFT ASSEMBLY	2 - 3	★
4830-738F	38"	RIGHT ASSEMBLY	LEFT ASSEMBLY	2 - 3	★
4830-740F	40"	RIGHT ASSEMBLY	LEFT ASSEMBLY	2 - 3	★
4830-830F	30"	LEFT ASSEMBLY	RIGHT ASSEMBLY	1 - 2	●
4830-836F	36"	LEFT ASSEMBLY	RIGHT ASSEMBLY	2 - 3	●
4830-838F	38"	LEFT ASSEMBLY	RIGHT ASSEMBLY	2 - 3	●
4830-840F	40"	RIGHT ASSEMBLY	LEFT ASSEMBLY	2 - 3	●
4830-930F	30"	RIGHT ASSEMBLY	LEFT ASSEMBLY	3 - 4	★

6. **SPRING SHANK** -- Loosen the 1-1/4NC Bolts (1) holding the side plates of the shank assembly and slide the shank between the plates. **NOTE:** If you ordered the optional no-till attachment, the no-till mounting plates and longer hardware should be assembled during this step. Use the 1NC x 4" special bolt (2), 5/8NC x 5" Cap Screw (3) and Lock Nuts to secure the shank. **TIGHTEN THESE UNTIL SNUG.**

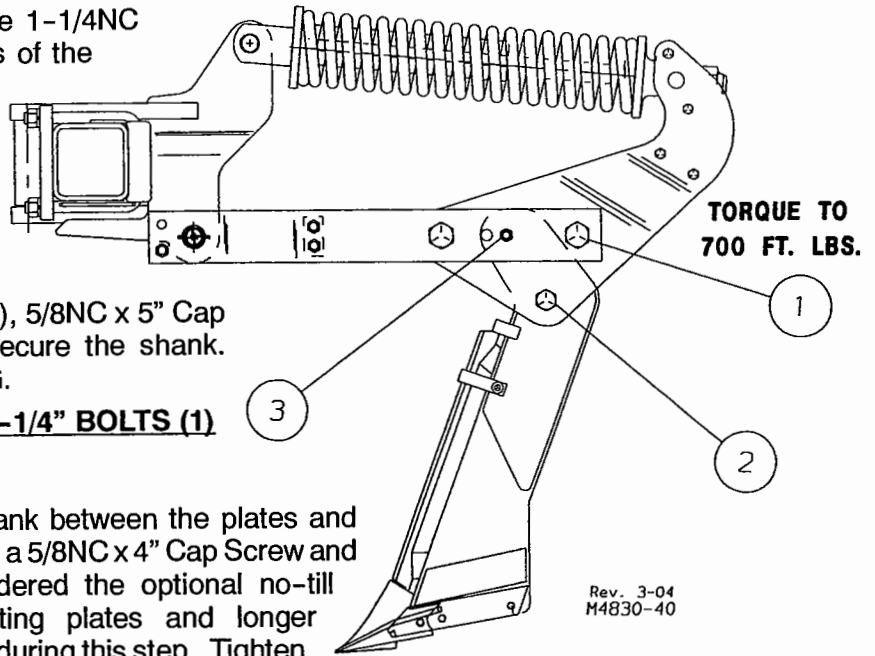

**IMPORTANT: TORQUE THE 1-1/4" BOLTS (1) TO 700 FT. LBS.**

7. **RIGID SHANK** -- Slide the shank between the plates and fasten using a 1NC x 4-1/2" Bolt, a 5/8NC x 4" Cap Screw and Lock Nuts. **NOTE:** If you ordered the optional no-till attachment, the no-till mounting plates and longer hardware should be assembled during this step. Tighten until snug.

8. Assemble the point and wear bar to the shank as shown in the parts section page P16.

### **NO-TILL ATTACHMENT**

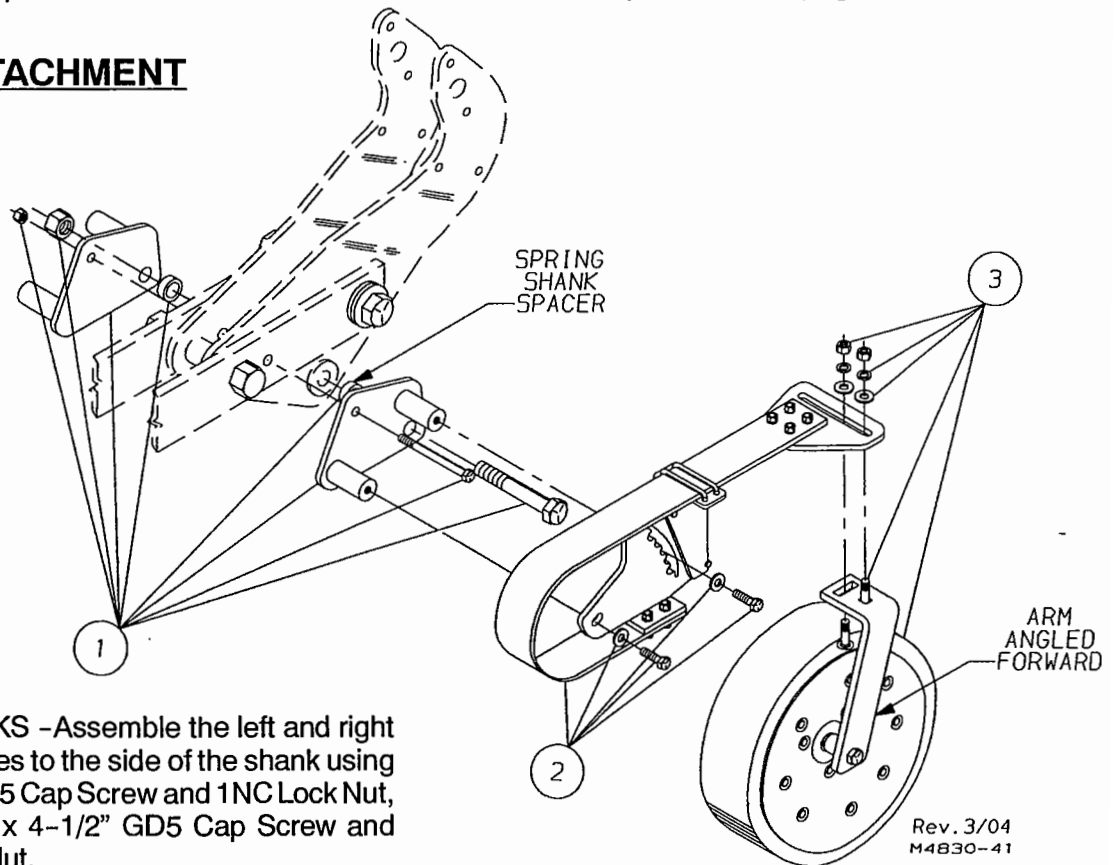

1. **RIGID SHANKS** - Assemble the left and right mounting plates to the side of the shank using a 1NC x 5" GD5 Cap Screw and 1NC Lock Nut, and a 5/8NC x 4-1/2" GD5 Cap Screw and 5/8NC Lock Nut.

**SPRING SHANKS** - use a 5/8NC x 5-1/2" Cap Screw and 5/8NC Lock Nut. Insert a 1/2" thick spacer bushing between the shank plate and mounting plate on the 1" x 6" Bolt (see illustration above).

2. Assemble right and left spring assemblies to mount plates using flat washers and 1/2NC x 1-1/2" Cap Screws.
3. Assemble right and left wheel arms to rear of spring assemblies using 1/2NC x 2" Carriage Bolts, Flat Washers, Lock Washers and Hex Nuts. Assemble with the right and left wheel arms with the arm angled forward and the hardware as shown above.

## FOLD LINKAGES AND HYDRAULICS

Refer to the illustration shown at right.

4. Assemble the two curved Linkages (1), Spacer Bushing (2) and two Flat Washers (7) between the lugs on the center frame using a 1-1/4"DIA. x 8-7/8" Pin (3), 3/8" DIA. x 2" Roll Pins and two Flat Washers on the outside of the center frame lugs.
5. Assemble the two straight Linkages (4) with four Flat Washers (7) to the outside of the lugs on the wing frame using a 1-1/4" DIA. x 6-1/4" Pin (5) and 3/8" DIA. x 2" Roll Pins. Assemble the Washers as shown.

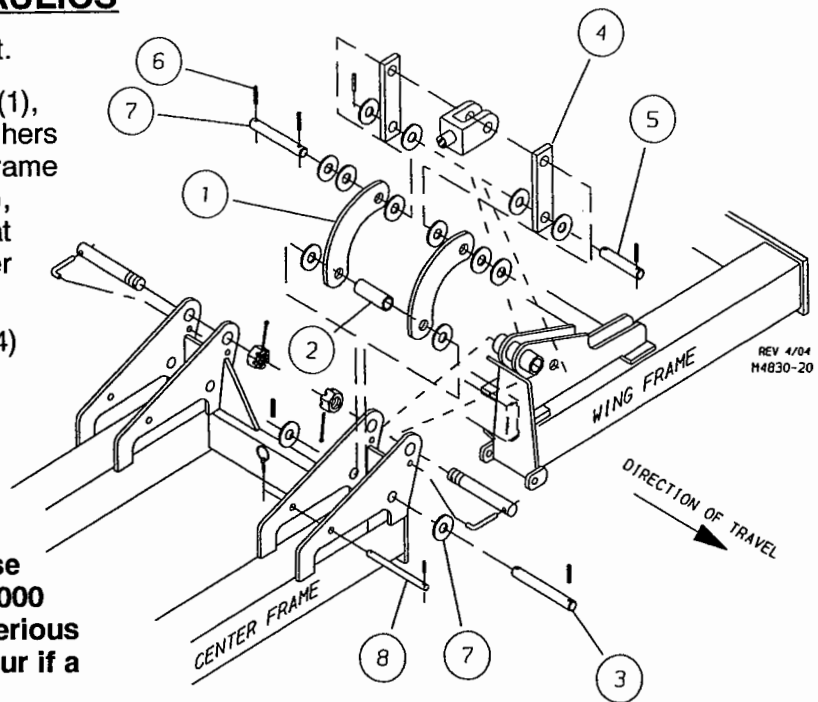

**Warning:** Use only hydraulic hose that meets or exceeds 3,000 psi working pressure. Serious injury or death may occur if a hose ruptures.

**Warning:** Do not pin the fold cylinder in place until all hydraulic assembly is complete and system has been purged of air and filled with oil. Serious injury or death may occur due to falling wings.

6. Place the fold cylinders on the center frame near where they are to be pinned. Be sure rod can extend without any interference.
7. **HYDRAULICS - -**

Note: No tape or sealant is necessary on O-Ring / 37° Flare Fittings.

Refer to the parts section pages P16-19 for the correct assembly of hoses, fittings and hose clamps.

**IMPORTANT:** A 90° RESTRICTOR SHOULD BE ASSEMBLED INTO BOTH ROD AND BASE END PORTS OF EACH WING LIFT CYLINDER. The restrictor can be identified by a tag attached to it. Proper location of these fittings is important to prevent the implement wings from free-falling if a hydraulic failure should occur.

After all connections have been made and tightened, connect the hoses to a tractor and cycle the fold cylinders. Continue the cycles until the cylinders respond with immediate solid actuation. Hold the control lever open and pause at the end of each stroke to purge the air from the system.



**Warning:** Escaping fluid under pressure can penetrate the skin causing serious injury or death. Avoid the hazard by relieving pressure before disconnecting hydraulic lines. Tighten all connections before applying pressure.

Search for leaks with a piece of cardboard. Protect hands and body from high pressure fluids.

If an accident occurs, see a doctor immediately. Any fluid injected into the skin must be surgically removed within a few hours or gangrene may result.

8. Retract the cylinders and pin the base to the cylinder lug on the main frame. Pin the ram between the curved and straight Fold Links using Flat Washers (7), a 1-1/4" DIA. x 8" Pin (6), and 3/8" DIA. x 2" Roll Pins as shown in the illustration above.
9. Place a Fold Lock Pin (8) in its storage position at each center frame hinge lug and secure with a 1/4" DIA. x 1-1/2" Roll Pin and 3/16" DIA. Klick Pin.

## **PULL HITCH ASSEMBLY**

Refer to the parts section pages P7 to P9 for assembly illustrations of pull hitch and lift wheel assembly. Assemble as shown.

### **Lift Wheel Mount Locations**

1. The Lift Wheel Mount assembles to the front of the center frame with the wheels in front of the unit. Counting from the centerline of the unit:

On all 5, 7 & 9 Shank Models, as well as 4 Shank 40", 6 Shank 30" & 8 Shank 36" Models, place the lift wheel between the 2nd and 3rd coulters (the center coulters are number 1 on odd shank units). On all other 6 and 8 Shank Models, place the lift wheel between the 1st and 2nd coulters from centerline.

### **2. HYDRAULICS - -**

 **Warning:** Use only hydraulic hose that meets or exceeds 3,000 psi working pressure. Serious injury or death may occur if a hose ruptures.

 **Warning:** Do not pin the lift cylinder in place until all hydraulic assembly is complete and system has been purged of air and filled with oil. Serious injury or death may occur due to unit lowering.

Place the lift cylinders on the center frame near where they are to be pinned with the rod ends above the base end. Be sure rod can extend without any interference.

Note: No tape or sealant is necessary on O-Ring / 37° Flare Fittings.

Note: The larger 4-1/4" Diameter cylinder is placed on the left hand lift wheel.

Refer to the parts section page P20 to P23 for the correct assembly of hoses, fittings, and hose clamps.

After all connections have been made and tightened, hook the hoses to a tractor and cycle the lift cylinders until the cylinders respond with immediate solid actuation. When the cylinders reach full extension, hold the tractor lever engaged to let the oil bypass the 4-1/4" series cylinder and go on to the 4" series cylinder and then back to the tractor. If you do not hold the lever, the air between the cylinders will not be purged and the system will not function properly.



 **Warning:** Escaping fluid under pressure can penetrate the skin causing serious injury or death. Avoid the hazard by relieving pressure before disconnecting hydraulic lines. Tighten all connections before applying pressure.

Search for leaks with a piece of cardboard. Protect hands and body from high pressure fluids.

If an accident occurs, see a doctor immediately. Any fluid injected into the skin must be surgically removed within a few hours or gangrene may result.

3. After the cylinders have been purged of air, pin them to the wheel lift assemblies.

 **Warning:** The unit is considerably tail heavy with the pull hitch. The tongue will raise rapidly when raising the unit if it is not hitched to a tractor. Serious injury or death may occur. See the instructions for Hitching and Unhitching the unit in the Operating Section of this manual.

## **SHANK STAGGER KIT**

STAGGER KIT PLACEMENT:    Model 530R -- Start with first shank right or left of center.  
   Model 730R -- Start with center shank.  
   Model 730F -- Start with first shank right or left of center.  
   Model 930F -- Start with center shank.

 **Caution:** Ripper shank assemblies can weigh as much as 400 lbs. Use suitable lifting equipment when removing assemblies. Failure to do so could cause serious injury.

Remove the ripper shank assembly from frame and attach the stagger weldment to the rear of the frame using a bolt plate and (4) each 1NC x 9" Machine Bolts, Lock Washers and Hex Nuts. Torque the 1" Hardware to 625 ft. lbs. Check to be sure that the stagger weldment clamps over the frame box and that the plate is tight down against the frame. Assemble the ripper shank assembly to the stagger weldment.

Note: On the Pathfind'r™ swing shank assembly torque the 7/8" U-Bolts to 400 ft. lbs. and the 1-1/4" pivot pin weldment to 530 ft. lbs.

On the rigid or spring cushion shank assembly tighten the 5/8" clamp bolts until the top clamp leg is parallel to the lower clamp leg.

## **DECAL ATTACHMENT AND SMV EMBLEM**

It is very important that all decals are in place on the ripper as shown in the parts drawing on page P30 of this manual. These decals, reflectors, safety, and operating messages are just as important as the parts that have been assembled.

Note: Wipe frame members clean before applying decals for better adhesion. If decals or reflectors should become faded or damaged be sure to replace them. Assemble the SMV sign to the frame with the hardware provided (see illustration on page P1). Follow the guidelines for placement given on page O5 of this manual.

## LIGHT BRACKET ASSEMBLY

Assemble the light brackets as shown in the following illustration and written steps. Refer to the parts drawing on page P28 of this manual for detailed part call-out information.

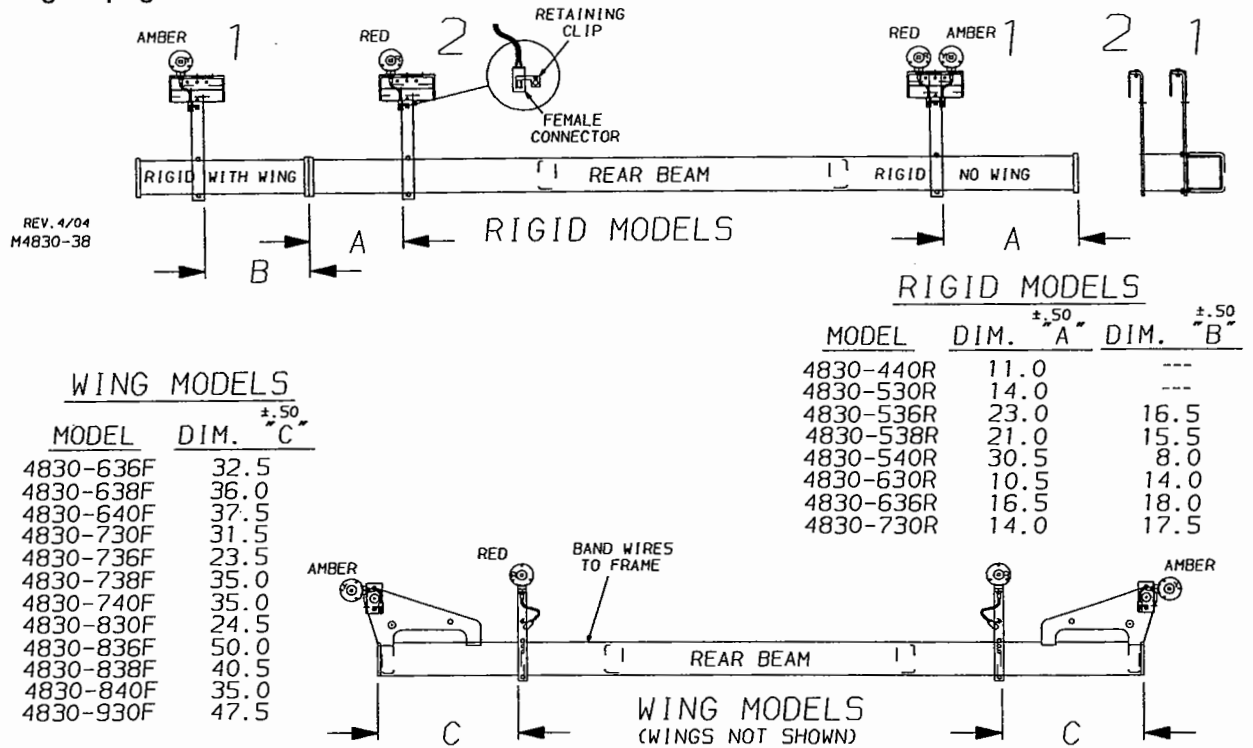

### Rigid Frame Unit with no Wing

1. Assemble a red reflector plate, a yellow reflector plate, an amber light, and a red light to a light stand using a 3/8NC x 1-1/4" Cap Screw, Flat washer, Lock Washer and Hex Nut.

Note: The red reflectors face the rear of the unit and the yellow reflectors face the front. The amber light is to the outside of the unit and red light is mounted to the inside.

2. Assemble the second stand for the opposite side.
3. Use dimension "A" for your model from the chart to fasten the two assemblies to the rear of the frame at the proper location.

### Rigid Frame Unit with Wing

1. Outside Bracket Assembly -- Assemble a red reflector plate, a yellow reflector plate, and an amber light to a light stand using a 3/8NC x 1-1/4" Cap Screw, Flat Washer, Lock Washer, and Hex Nut.
2. Assemble a second similar stand for the opposite side.
3. Inside Bracket Assembly -- Assemble one red reflector plate and a red light to a light stand using a 3/8NC x 1-1/4" Cap Screw, Flat Washer, Lock Washer and Hex Nut.
4. Assemble a second similar stand for the opposite side.
5. Use dimensions "A" and "B" for your model from the chart to fasten the FOUR assemblies to the rear of the frame at the proper location.

### Folding Unit

1. Use dimension "C" for your model from the chart to fasten the light stands to the frame at the proper location.

### Wire Harness

The metal retaining clips provided slide into the slot on the back of the female connectors. Fasten the connections to the light brackets using a 1/4NC x 1" GD5 Cap Screw with Flat Washer, Lock Washer and Hex Nut. Fasten the wire harness to the frame using stay straps provided.

**This page intentionally left blank.**





# SAFETY FIRST

Be observant and safety minded. Recognize and correct or avoid hazardous conditions before an accident can happen. Most accidents can be prevented by practicing simple fundamental safety rules.

1. Read and understand the implement and tractor owner's manuals before operating.
2. Be sure safety decals and reflectors are clean and in place.
3. Do not climb or walk on gangs or frames or tires.
4. Never position yourself under any portion of implement unless the transport lock is engaged or entire unit is lowered to the ground.
5. Stop engine before leaving the operator's position to adjust, lubricate, clean or unclog the machine.
6. Do not stand between the implement and tractor unless the tractor brakes are locked and engine is shut off.
7. Do not stand on or straddle a tongue when unhitching.
8. Always store a winged implement with the wings down.
9. Never remove locking pins until hydraulic cylinders and lines are full of oil and free of air. See Operating Instructions for proper method of removing air.
10. Never use machinery until all safety devices are in place.
11. Release all hydraulic pressure before shutdown periods.
12. Comply with Federal, State and local laws.
13. Use a Slow-Moving-Vehicle (SMV) emblem when transporting.
14. Always use a safety chain of tensile strength equal to the gross weight of the implement and attachments when roading.
15. Towing vehicle weight must exceed weight of towed implement.
16. Check wheel bolts before and during transport.
17. Always use wing locks and road locks to hold raised positions.
18. Never permit riders on implement.
19. Do not road an implement over 15 miles per hour on the best surface conditions. Reduce speed when going up or down hills and when approaching ditches.
20. Keep small children away from farm equipment.
21. Never modify an implement without permission from the Krause Engineering Department.
22. Always use authorized Krause parts.